

FORSTER PRODUCTS

310 SE LANARK AVENUE, LANARK, ILLINOIS 61046 PHONE: 815-493-6360 FAX: 815-493-2371 www.forsterproducts.com

User Instructions for Primer Seater Assembly for the Co-Ax® XL Reloading Press

Issue 1

1.0 PRIMER SEATING

1.1 Primer Seating Overview

Proper priming is one of the most critical operations in the reloading process. In order for your ammunition to perform efficiently, consistent ignition is absolutely mandatory. For this reason, we paid special attention to the priming function in the design of Co-Ax XL Press.

The primer seater design is engineered with such precision that no excessive tolerance or “slop” is required in any of the mating parts. The primer post in the Primer Seater Assembly (see Figure 1) moves freely in its channel with minimal clearance. This extremely tight tolerance delivers remarkably consistent seating depth, time after time.

Regardless of the variation in the dimension of the case rim or the amount of force used in seating the primer, with the Forster Products Co-Ax XL Press, it is impossible to crush a primer or vary the seating depth.

Figure 1. Primer Seater Assembly Function

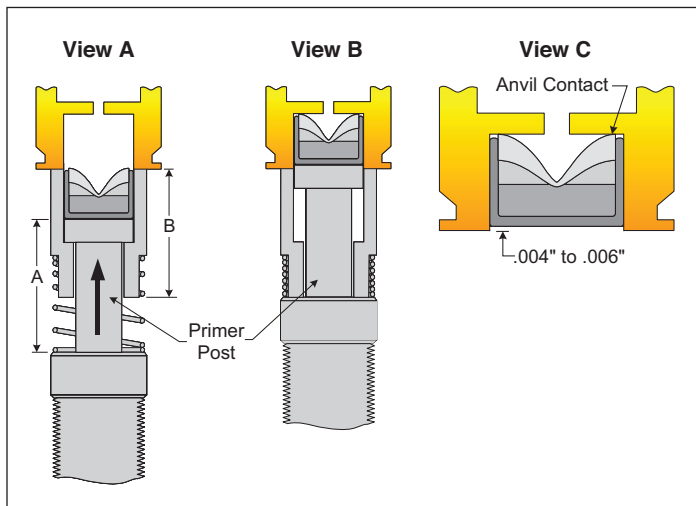

View A: Dimension “A” is greater than dimension “B” by .004” to .006”.

View B: When force is applied to the guide block of the press, the bottom of the primer cup stops against the base of the primer post. The top of the primer cup stops against the case head. Because the primer post is longer than the cup by .004” to .006”, the primer will always be seated .004” to .006” below the case head as shown in **View C**.

1.2 ADJUST CO-AX XL PRESS

1.21 Primer Seater Assembly

Based on the primer diameter being used, select either the Large Primer Seater Assembly or the BMG Primer Seater Assembly (see Figure 2) and screw it into Co-Ax XLPress.

Figure 2. Primer Seater Assembly Versions

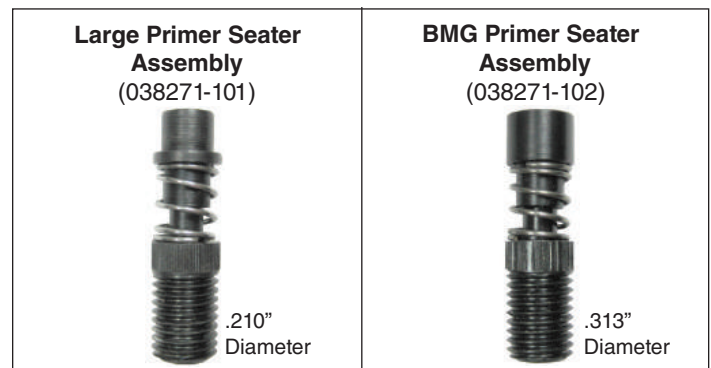

1.22 Top Shell Holder Jaws

Based on the thickness of the case rim being primed, ensure all three ends of the Top Shell Holder Jaws are matched and aligned, and held loosely face down on the Shell Holder Jaw Block (038271-117). Note the stamped circle that indicates which ends are aligned.

Figure 3. Top Shell Holder Jaws (038271-016)

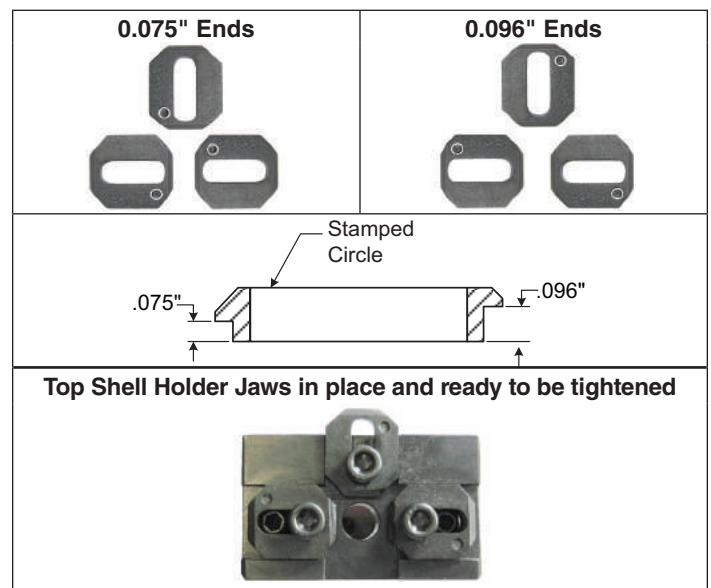

1.23 Locator

1. Match the Locator end to the primer diameter being used (Figure 4).

Figure 4. Locator (038271-018)

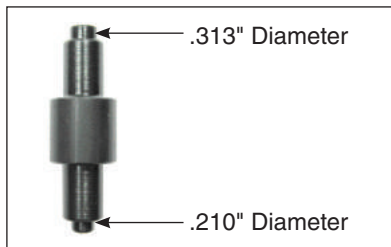

2. Lower the Co-Ax XL Press Handle until there is enough room to insert the Locator up into the Top Shell Holder Jaw Block (038271-117) from underneath.
3. Center an unprimed case on the Locator.
4. While holding the locator in place, adjust the three Top Shell Holder Jaws inward onto the case rim and tighten the three Socket Head Cap Screws (SCR10-24X1/2SHEADCAP) around the case. Do not overtighten. (See Figure 5.)

Figure 5. Locator in Use

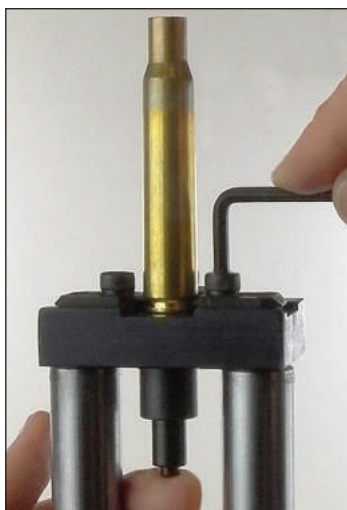

5. Lower the Co-Ax XL Press handle and remove the Locator. You are now ready to prime. If the case rim is either too loose or too tight, try using the opposite end of the Top Shell Holder Jaws.

1.3 Prime Your Cartridges

NOTICE

Wear thin medical gloves on the primer hand to improve the grip and help keep the primer from contamination.

1. Insert the primer on the Primer Seater Assembly and the case on the Top Shell Holder Jaws following the instructions below.

⚠ WARNING PERSONAL INJURY

Failure to comply with these instructions could result in death or serious injury.

2. Use one of the two following positions for inserting the primers on the Primer Seater Assembly and the cases on the Top Shell Holder Jaws:

Left-handed primer handling:

- A. Facing the press, take a position to the left of the press.
- B. Lower the handle forward approximately 90°.
- C. From the rear of the press, use your left hand to insert the primer and the right hand to insert the case.



Right-handed primer handling:

- A. Facing the press, take a position to the right of the press.
- B. Lower the handle forward approximately 90°.
- C. From the rear of the press, use your right hand to insert the primer and the left hand to insert the case.



3. Raise the Co-Ax XL Press handle to seat the primer. Only a very small amount of force is needed.

WARRANTY

All Forster Products are warranted against defects in materials and workmanship for the life of the product. Parts excluded from the warranty are those that, by nature of their function, are subject to normal wear (such as springs, pins, etc.) or that have been altered, abused, or neglected. If the product is deemed defective by workmanship or materials, it will be repaired, reconditioned or replaced (at Forster's option). This warranty supersedes all other warranties for Forster Products, whether written or oral.