

FORSTER PRODUCTS

310 E. LANARK AVENUE, LANARK, ILLINOIS 61046 PHONE: 815-493-6360 FAX: 815-493-2371 www.forsterproducts.com

User Instructions for the 3-in-1 Case Mouth Cutter

Issue 13

1.0 GENERAL INFORMATION

In one easy operation, the 3-in-1 Case Mouth Cutter simultaneously does the following (see Fig. 1):

- Trims the case to length.
- Chamfers the inside case mouth to an angle of 14° (correct for boat-tailed VLD (Very Low Drag) bullets as well as for traditionally-shaped bullets).
- Chamfers the outside case mouth to an angle of 30°.

Figure 1. Function

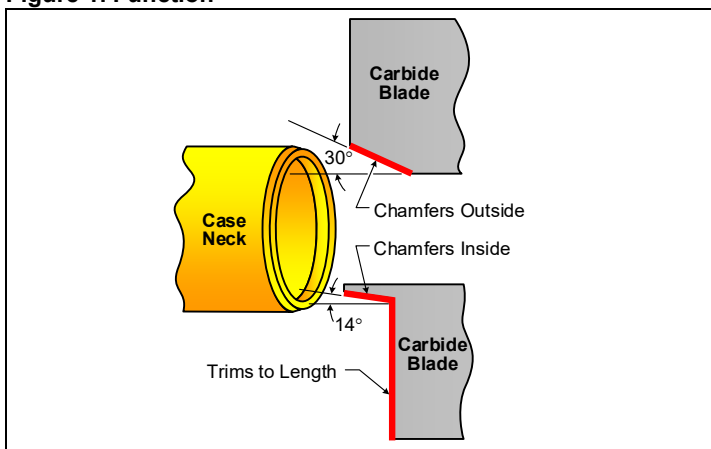

The 3-in-1 Case Mouth Cutter is an accessory to your **Original Case Trimmer (CT1010)**. It may also be used on your **Power Case Trimmer (PT1010)**.

The 3-in-1 fits over the Cutter Shaft and easily secures with one Set Screw (see Fig. 2).

- Long-lasting Carbide Blades are set at the factory.
- Carbide Blades should never need sharpening when used on brass cases.
- Available in multiple calibers.
- Pilots are finished with black oxide to prevent confusion with standard Case Trimmer pilots which do not have this finish.

Figure 3. Assembly on Original Case Trimmer

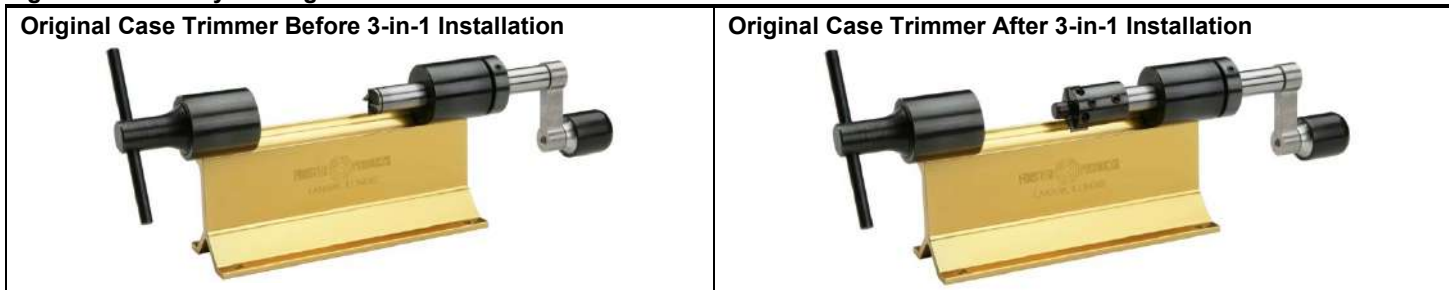

NOTICE

Pilots are not interchangeable between calibers due to the difficulty of setting the carbide cutters to the correct position, which must be done at the factory.

Figure 2. Nomenclature

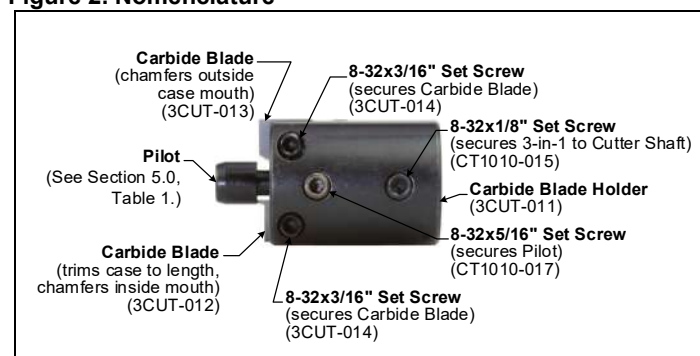

2.0 SAFETY INFORMATION

Always wear safety glasses.

3.0 PREPARATION

3.1 Assemble the following:

- 3-in-1 Case Mouth Cutter.
- Your Original Case Trimmer or Power Case Trimmer.
- "User Instructions for the Original Case Trimmers" found under "Resources" on our website.

3.2 Install 3-in-1 Case Mouth Cutter on Original Case Trimmer (see Fig. 3):

- Consult "Original Case Trimmer User Instructions" to locate the O-Ring.
- Remove the O-Ring by rolling it over the Cutter Shaft. (Set the O-Ring aside for later reassembly when not using the 3-in-1.)
- Slide the 3-in-1 over the Cutter Shaft and secure with the Set Screw. Note that the fit is *very* close.

NOTICE

A longer CT base may be required for certain calibers. An adjustment of ½" (in ¼" increments) is built into the Original Case Trimmer, allowing its capacity to be widened before it becomes necessary to use a Long Base (6½"). To adjust, use the outer set of holes on the Collet Housing and Bearing to mount them to the Base.

4.0 PROCEDURE

4.1 Condition Cases

1. Consult "Original and Classic Case Trimmer User Instructions" for correct collet installation and proper trimming/ setting the trimming length information.
2. Condition cases.
3. Cases are now chamfered and trimmed to length, ready for priming, charging and bullet seating (see Fig. 4):

Figure 4. Prepared Cases



TIP

The Forster Case Trimmer Power Adapter (PA1000) allows your Original Case Trimmer to be powered by your electric screwdriver or power drill.

NOTICE

The Carbide Blade (3-CUT-013) that chamfers the OUTSIDE case mouth (see Fig. 1) is factory set for brass with a wall thickness of .012" and may need to be adjusted to account for very thick brass, such as .015". Use the 8-32x3/16" Set Screw that holds the Carbide Blade in the Carbide Blade Holder to move the Carbide Blade out to lessen the amount of OD chamfer.

DO NOT reset the Carbide Blade (3-CUT-012) that chamfers the INSIDE of the case mouth. Please see Section 6.1.

5.0 ORDERING INFORMATION

Table 1. Complete Product

Order Number	Description
3CUT-224	3-in-1 Case Mouth Cutter (Carbide) for 224, includes pilot
3CUT-243	3-in-1 Case Mouth Cutter (Carbide) for 243 (6mm), includes pilot
3CUT-257	3-in-1 Case Mouth Cutter (Carbide) for 257, includes pilot
3CUT-264	3-in-1 Case Mouth Cutter (Carbide) for 264 (6.5mm), includes pilot
3CUT-277	3-in-1 Case Mouth Cutter (Carbide) for 277, includes pilot
3CUT-284	3-in-1 Case Mouth Cutter (Carbide) for 284 (7mm), includes pilot
3CUT-308	3-in-1 Case Mouth Cutter (Carbide) for 308, includes pilot

Collet Ordering

Use our online database to determine which Collets are right for the job. Go to our website and click **Search by Caliber**.

6.0 CUSTOM MACHINING SERVICES

A complete list of services, including prices and lead times, is available on our website. Go to forsterproducts.com, then click **Custom Machining Services** under "Resources."

6.1 Carbide Blade Resetting in the Blade Holder

The long-lasting Carbide Blades are set at the factory. If they ever need resetting, we will be happy to do so. *Please return your 3-in-1 Case Mouth Cutter, along with three cases that are ready to trim. Do not send the entire Original Case Trimmer.* A nominal fee to cover the technician's time and shipping will be charged.

7.0 REPLACEMENT PARTS

Every product component is available individually. A complete list of component order numbers and prices is available on our website. Go to forsterproducts.com, then click **Replacement Parts**.

For best prices, contact your Forster distributor. Experienced distributors are an integral part of the shooting sports. Please make frequent use of their knowledge and support them. To find a Reseller, go to forsterproducts.com, then click **Distributors**. If your distributor cannot supply you, please contact us by email, fax, or phone.

WARRANTY

All Forster Products are warranted against defects in materials and workmanship for the life of the product. Parts excluded from the warranty are those that, by nature of their function, are subject to normal wear (such as springs, pins, etc.) or that have been altered, abused, or neglected. If the product is deemed defective by workmanship or materials, it will be repaired, reconditioned or replaced (at Forster's option). This warranty supersedes all other warranties for Forster Products, whether written or oral.