

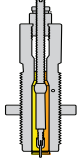

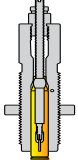





## Individual Dies

Bench Rest Reloading Die	Features		Reloader Experience Level
<b>Sizing Dies</b>			
<b>Full Length Sizing Die</b> 	<ul style="list-style-type: none"> <li>Sizes the case neck, shoulder and body, deprimers and expands the case neck.</li> <li>Used with any rifle of a specific cartridge (for example: any 220 Swift Die works for any 220 Swift rifle).</li> <li>Allows the case to be re-chambered in any SAAMI minimum size rifle chamber with minimal play.</li> <li>Available individually or as a set with a Bench Rest Seater Die.</li> <li>Machined with one-piece reamers to achieve phenomenal concentricity.</li> </ul>	  <p>Die Sizing Outside of Case and Removing Spent Primer      Die Beginning to Expand Case Neck</p>	All
<b>Bushing Bump Neck Sizing Die</b> 	<ul style="list-style-type: none"> <li>Sizes case neck for bullet tension, sizes shoulder to set headspace and deprimers</li> <li>Prevents overworking of case brass.</li> <li>Best for fine-tuning brass for use with a specific rifle.</li> <li>Uses .001" increment Bushings to fine-tune neck tension and bullet grip.</li> <li>Available individually or as a Kit with 3 pre-selected Bushings.</li> <li>Machined with one-piece reamers to achieve phenomenal concentricity.</li> <li>Custom size your cases to your rifle's chamber.</li> </ul>	  <p>Before Sizing      After Sizing</p> <p>Optimal Neck Diameter Optimal Headspace</p> <p><i>View exaggerated for clarity.</i></p>	Intermediate to advanced
<b>Seater Dies</b>			
<b>Seater Die</b> 	<ul style="list-style-type: none"> <li>Our innovative, caliber-specific sliding die chamber holds the bullet, case and seating stem in perfect alignment while the bullet is seated.</li> <li>Available individually or as a set with a Full Length Sizing Die.</li> <li>Non-crimping style provides accuracy, consistency, and virtually flawless alignment.</li> </ul>	   <p>Empty Die Chamber      Everything Aligned, Ready to Seat Bullet      Seated Bullet</p>	All
<b>Ultra™ Micrometer Seater Die</b> 	<ul style="list-style-type: none"> <li>Our innovative, caliber-specific sliding die chamber holds the bullet, case and seating stem in perfect alignment while the bullet is seated.</li> <li>Micrometer fine tunes your precise seating depth requirements.</li> <li>Use if you like to experiment with various bullets and loads for many different shooting applications.</li> <li>Non-crimping style provides accuracy, consistency and virtually flawless alignment.</li> </ul>	<p><i>*Bench Rest Seater Die is shown.</i></p>	All

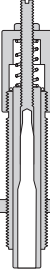
## Introducing the Bench Rest Die Set

One Full Length Sizing Die and one Bench Rest Seater Die



For every rifle caliber you own, we recommend that you have a Full Length Sizing Die and a Bench Rest Seater Die. The Bench Rest Die Set includes one Full Length Sizing Die and one Bench Rest Seater Die, all packaged in our Deluxe Die Box. See listings on pages 6-7.

### Custom Machining Services



We can manufacture custom versions of any of five Reloading Dies to your specifications.

# Bench Rest® Sizing Dies

## Features

- Manufactured from the finest quality steel.
- Carefully machined on super precision® chucking lathes to very tight tolerances.
- Manufactured with one-piece reamers to help guarantee concentricity between all machined diameters.
- Heat treated and oil quenched in atmospherically controlled furnaces to an extremely tough Rockwell hardness.
- Hand polished in a high-speed lathe both before and after heat treating guarantee an extra-fine finish.
- Equipped with our exclusive “E-Z” Out® Expander Ball, which helps solve the problem of keeping case necks concentric during the neck expanding operation.

The combination of our elevated “E-Z” Out Expander Ball and butyl rubber Co-Ax® Washer corrects misalignment of the Decapping/Expander Assembly and prevents the case neck from pulling off center during the expanding procedure.

Our design also reduces the effort required to draw the “E-Z” Out Expander Ball through the case neck because it takes full mechanical advantage of the power developed in the linkage of your press. The elevated position of the Expander Ball means that the expanding operation happens with the press handle near the bottom, where it produces the most leverage. The expanding operation is hardly felt, making sizing much less laborious.

## Full Length Sizing Die

Produces ammunition that has a “glove fit” to your chamber. Use after each firing or after several firings, when the resulting brass flow will require the case to be full-length sized.



Fig. 1 shows the “E-Z” Out® Expander Ball placed high on the Spindle in the Decapping/Expander Assembly, near the neck of the case.

Fig. 2 shows the case being withdrawn from the Die. Note how the elevated position of the “E-Z” Out® Expander Ball supports the case neck in the neck sizing portion of the Die, keeping the axis of the neck and the case in perfect alignment.

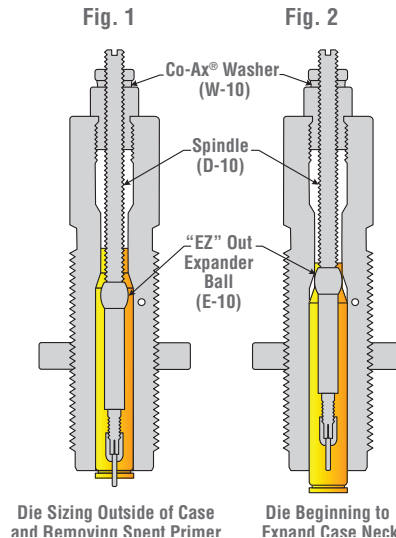

## Web



The “E-Z” Out Expander Ball system requires that the Decapping/Expander Assembly be adjusted properly at all times. The Decapping/Expander Assembly is set at the factory; however, if the “E-Z” Out Expander Ball is readjusted and set too high in the die, case neck and spindle damage will result. Our website has complete user instructions.

## Features

- Sizes the case neck, shoulder, and body. Deprimes and expands the case neck. Allows the case to be re-chambered in a SAAMI minimum size rifle chamber.
- Precisely positioned vent hole located in the threaded or recessed portion of the die body prevents excessive, trapped air and lubrications from damaging the die's components or your cases.

**Note:** When using military brass with crimped primers, use a decapping die first to remove spent crimped primers (not available from Forster Products).

## Ordering Information

Full Length Sizing Dies are available in more than 70 calibers, either individually or as part of the Bench Rest Die Set with a Bench Rest Seater Die. **Die ordering information begins on page 6.**

## Custom Machining Services



We can custom hone up to .008" the inside neck diameter of our Full Length Sizing Dies. Custom honing is a diamond stoning process that enlarges the inside diameter of the Die and will prevent oversizing of the case neck due to thick neck walls. You may need this service:

- If you use some brands of brass cases, such as Norma or Lapua, that have thicker neck walls.
- If you do not intend to outside neck turn case necks that have thickened after repeated firings.

See our website for details.

# Bench Rest® Sizing Dies

## Bushing Bump Neck Sizing Die

Developed with input from some of the world's most discriminating reloaders and competitive shooters, our unique design allows precise case neck and shoulder sizing in one easy step.

### Features

- Sizes the case neck and shoulder to set headspace and deprimers.
- One-step bushing reduction/bump operation sets the shoulder back to keep your case neck in better alignment with the case's center line.
- Prevents overworking of case necks, as well as controls the amount of neck tension for your bullet seating operation.
- Over 90 available bushings allow case necks to be sized to your exact requirements.
- Versatility allows you to custom size your cases to your specifications.



### Partial Neck Sizing

You can adjust the bushing to allow partial case neck sizing, allowing the unsized section to better align the cartridge in the rifle chamber.

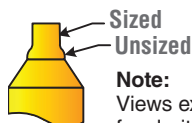

**Note:**  
Views exaggerated for clarity.

### Bump the Shoulder without Changing the Case Neck Diameter

By removing the neck bushing, you can use the Bushing Bump Neck Sizing Die to bump just the case shoulder without changing the neck diameter. This action maintains proper headspace in any chamber, custom or factory setting.

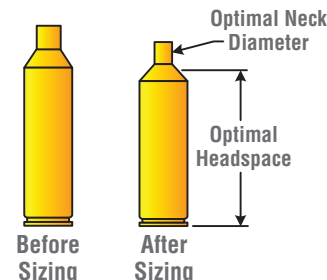

### Ordering Information

Bushing Bump Neck Sizing Dies are available either individually or in a kit with three pre-selected bushings most likely needed to produce accurate ammunition with proper neck tension. The kit also includes our Deluxe Die Box.



Die ordering information begins on page 6.

Bushings are available separately. If you're making cartridges for a tight chambered rifle, you might need smaller bushings. Alternatively, you might need larger bushings if you are not outside neck turning and are using brass cases with thick neck walls. Most sizes are available in .001" increments; just order by the inside diameter desired.

See Table 1 for Bushing ordering information.

**Table 1. Order Guide for Bushing Bump Neck Sizing Die Bushings**

Bush-222	Bush-286
Bush-223	Bush-287
Bush-224	Bush-288
Bush-225	Bush-289
Bush-226	Bush-290
Bush-227	Bush-291
Bush-228	Bush-292
Bush-229	Bush-293
Bush-230	Bush-294
Bush-240	Bush-295
Bush-241	Bush-296
Bush-242	Bush-297
Bush-243	Bush-298
Bush-244	Bush-299
Bush-245	Bush-300
Bush-246	Bush-301
Bush-247	Bush-302
Bush-248	Bush-303
Bush-249	Bush-304
Bush-250	Bush-305
Bush-251	Bush-306
Bush-252	Bush-307
Bush-253	Bush-308
Bush-256	Bush-309
Bush-257	Bush-310
Bush-258	Bush-311
Bush-259	Bush-312
Bush-260	Bush-313
Bush-261	Bush-315
Bush-262	Bush-323
Bush-263	Bush-324
Bush-264	Bush-325
Bush-265	Bush-326
Bush-266	Bush-327
Bush-267	Bush-328
Bush-268	Bush-329
Bush-269	Bush-330
Bush-270	Bush-331
Bush-271	Bush-332
Bush-272	Bush-333
Bush-273	Bush-334
Bush-274	Bush-335
Bush-275	Bush-336
Bush-278	Bush-337
Bush-279	Bush-338
Bush-280	Bush-339
Bush-281	Bush-340
Bush-282	Bush-341
Bush-283	Bush-342
Bush-284	Bush-343
Bush-285	

Order number equals inside diameter of Bushing.

**Example:** Order Number Bush-230 is a Bushing with an inside diameter of .230".

# Bench Rest® Seater Dies

## Features

- Innovative, caliber-specific Die Chamber (Fig. 3) holds the case, the bullet, and the seating stem all in perfect alignment; supporting the entire outside diameter of the sized case rather than just the bullet and case neck. (Most competitors' products support only the case rim.)
- Non-crimping style provides accuracy, consistency, and perfect alignment. (Exception: 30-30 caliber Die does crimp.)
- Seating stems supplied with our standard seaters match even special bullet needs such as those encountered during the loading of most Very Low Drag (VLD) bullets.

The secret to perfect alignment is holding the bullet, case and seating stem in the same close fitting chamber for the entire seating operation.

Fig. 3 shows how both the bullet and the entire case are held in perfect alignment while the bullet is seated.

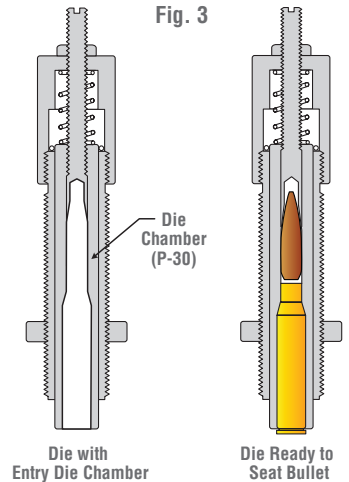

## Bench Rest Seater Die

First die of its kind on the market and is still the best straight line Seater Die available.

### Feature

- Holds both the bullet, case and seating stem in perfect alignment while the bullet is seated.



Fig. 4 shows how the bullet is held in the same close-fitting chamber for its entire length.

Fig. 5 shows the position of the sliding Die chamber (P-30) after the bullet has been seated.

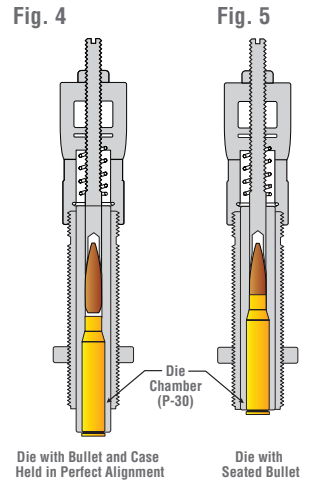

### Ordering Information

Bench Rest Seater Dies are available in more than 70 calibers or as part of the Bench Rest Die Set with a Full Length Sizing Die.

Ordering information begins on page 6.

## Bench Rest Ultra™ Micrometer Seater Die

Fine adjustments for precise seating measurements the very first time.

### Ordering Information

Ultra Micrometer Bench Rest Seater Dies are available in more than 70 calibers.

Ordering information begins on page 6.



Fig. 6 shows how the bullet is held in the same close-fitting chamber for its entire length.

Fig. 7 shows the position of the sliding Die chamber (P-30) after the bullet has been seated.

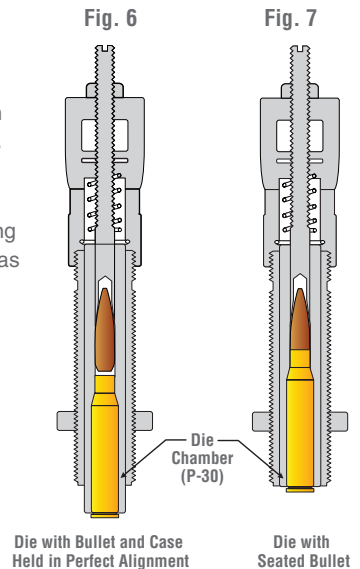

## Features

- Includes all the popular straight line seating features of our original Bench Rest Seater Die plus an ultra accurate micrometer for adjusting bullet seating depth.
- Micrometer allows fine adjustments in either direction; easily adjustable to .0005". Index marks at increments of .001" are clearly marked.
- After you have seated your bullet close to the desired depth and measured it, simply adjust the micrometer stem down to the desired depth and the cartridge will be exactly the length you need.
- Eliminates much of the trial and error that was once associated with seating accurate rounds.
- Bright, white markings make micrometer easy to read.

# Bench Rest® Reloading Die Tools

## Cross Bolt Die Lock Ring

Clamps around the entire die, resulting in a more precise mating of the lock ring threads to the die threads.



DIE-G-10

### Features

- Easy-to-use cross bolt connects the two ends of the ring instead of a traditional screw design that tightens directly into the threads of the die, resulting in a more precise mating of the lock ring threads to the die threads.
- Provides a more reliable alignment with no canting, and no damage to the die threads, which remain undamaged.
- Standard equipment on all Forster Products high-quality Sizing and Seater Dies.
- Tightening or loosening the steel cross bolt screw requires only a 7/64" hex key (Allen wrench).
- Fits standard 7/8"-14 thread dies from most manufacturers.

Order No.	Description
DIE-G-10	Cross Bolt Die Lock Ring (single ring)
DIE-G-10-DOZEN	Cross Bolt Die Lock Ring (pack of one dozen)

## Stuck Case Remover

The easy way to remove the Decapping Rod and Expander Ball when a case is stuck in the Die.



SC1000

Product in Use

### Features

- Designed for use with Forster Sizing Dies which feature the elevated "E-Z" Out Expander Ball in the Decapping/Expander Assembly.
- May also be used with sizing dies that use 1/4"-28 or 10-32 thread spindles.
- All components hardened for long life.
- Washer protects the top of your die.

Order No.	Description
SC1000	Stuck Case Remover

## Oversize "E-Z" Out® Expander Balls for our Bench Rest Sizing Dies

Oversize "E-Z" Out Expander Ball shown on Spindle (not included)



Oversize "E-Z" Out Expander Ball

6-40 internal thread		
.204" Bullet Dia.	.224" Bullet Dia.	.243" Bullet Dia.
Order No.	Order No.	Order No.
E-10-2040	E-10-2240	E-10-2430
E-10-2045	E-10-2245	E-10-2435
E-10-2050	E-10-2250	E-10-2440
10-32 internal thread		
.264" Bullet Dia.	.284" Bullet Dia.	.308" Bullet Dia.
Order No.	Order No.	Order No.
E-10-2640	E-10-2840	E-10-3080
E-10-2645	E-10-2845	E-10-3085
E-10-2650	E-10-2850	E-10-3090

Order No. is actual diameter. For example, Order No. E-10-2045 is an Oversize "E-Z" Out Expander Ball with a diameter of .2045".

# Bench Rest® Sizing and Seater Dies Order Guide

**Table 2. Bench Rest Sizing and Seater Dies Order Guide** (listed from smallest to largest bullet diameter)

Cartridge Name	Sizing Dies			Seater Dies		Die Sets
	Full Length Sizing Die	Bushing Bump Neck Sizing Die	Bushing Bump Neck Sizing Die Kit (1 die & 3 bushings)	Bench Rest Seater Die	Ultra Micrometer Seater Die	1 Full Length Sizer + 1 Bench Rest Seater
17 Rem	005091	—	—	005771	—	004011
204 Ruger	004271	BBD3101	BBK2101 (.228", .226", .224")	005121	U00002	004021
22 BR	018101	—	—	018141	U00007	004051
22 Hornet	007941	—	—	005801	U00004	004041
22 Nosler	005231	BBD3111	BBK2111 (.247", .249", .251")	005831	U00011	004065
22 PPC	005131	—	—	005821	U00010	004061
22-250 Rem	005221	BBD3191	BBK2191 (.251", .249", .247")	005901	U00031	004141
220 Swift	005211	—	—	005891	U00028	004131
221 Fireball	005141	—	—	018151	U00013	004071
222 Rem	005161	—	—	005841	U00016	004081
222 Rem Mag	005171	—	—	005851	U00019	004091
223 Rem	005181	BBD3141	BBK2141 (.247", .245", .243")	005861	U00022	004101
223 WSSM	005198	BBD3171	BBK2171 (.266", .264", .262")	005871	U00023	004111
224 Valkyrie	005185	—	—	005865	U00024	004105
224 Wby Mag	005191	—	—	008671	U00200	006921
5.6x50 Rimmed	005201	—	—	005881	U00025	004121
240 Wby Mag	005241	—	—	008681	U00201	006931
243 Win	005251	BBD3221	BBK2221 (.272", .270", .268")	005931	U00034	004171
243 WSSM	005261	BBD3241	BBK2241 (.284", .282", .280")	005941	U00035	004175
6mmx45 (6x223 Rem)	005295	—	—	005975	U00045	004265
6x47 Lapua	005265	BBD3251	BBK2251 (.270", .268", .266")	005945	U00036	004176
6mm BR	018121	BBD3301	BBK2301 (.268", .266", .264")	018161	U00037	004181
6 Creedmoor	005275	BBD3281	BBK2331 (.270", .272", .274")	005943	U00039	004177
6mm Dasher	005266	—	—	005946	U00038	004186
6mm PPC	005271	BBD3351	BBK2351 (.260", .258", .256")	005951	U00040	004191
6mm Rem (244)	005281	—	—	005961	U00043	004201
6mm XC	005291	—	—	005971	U00044	004261
25-06 Rem	005301	BBD3861	BBK2861 (.284", .282", .280")	005981	U00046	004221
25 WSSM	005321	BBD3401	BBK2401 (.298", .296", .294")	005911	U00050	004211
257 Ackley (40°)	023711	—	—	023921	U00052	022431
257 Roberts	005331	—	—	006001	U00055	004241
257 Wby Mag	005341	—	—	008791	U00202	007071
260 Rem (6.5-08)	005345	BBD3131	BBK2131 (.292", .290", .288")	006011	U00056	004251
6.5-284	005371	BBD3410	BBK2410 (.293", .291", .289")	006061	U00060	004281
6.5x47 Lapua	005346	BBD3261	BBK2261 (.291", .289", .287")	006015	U00057	004255
6.5 Creedmoor	005348	BBD3271	BBK2271 (.292", .290", .288")	006020	U00062	004253
6.5 Grendel	005347	—	—	006017	U00059	004256
6.5 PRC	005349	BBD3409	BBK2409 (.292", .290", .288")	006016	U00058	004254
6.5x57 Mauser	005381	—	—	018181	U00061	004291
6.5x55 Swedish	005401	BBD3420	BBK2420 (.293", .291", .289")	006071	U00064	004311
6.5x55 SKAN	005621	—	—	006071	U00064	004612
6.8 SPC	005391	—	—	006051	U00068	004622
26 Nosler	005335	BBD3411	BBK2411 (.288", .290", .292")	006021	U00063	004250
270 Wby Mag	005431	—	—	008841	U00203	007161
270 Win	005421	BBD3501	BBK2501 (.303", .301", .299")	006091	U00070	004331
270 WSM	005411	—	—	006085	U00071	004321
28 Nosler	005525	BBD3511	BBK2511 (.311", .313", .315")	008121	U00081	004222
7x57 Mauser	005471	—	—	006141	U00079	004381
7x64 Brenneke	007971	—	—	008101	U00073	004351
7mm-08	007981	BBD3541	BBK2541 (.308", .306", .304")	008111	U00076	004361
7mm BR Rem	018231	—	—	018241	U00082	018211

**Note:** Only Die Sets come in the Deluxe Die Box. Die Boxes can be ordered separately.

# Bench Rest® Sizing and Seater Dies Order Guide

**Table 2 (cont'd). Bench Rest Sizing and Seater Dies Order Guide** (listed from smallest to largest bullet diameter)

Cartridge Name	Sizing Dies			Seater Dies		Die Sets
	Full Length Sizing Die	Bushing Bump Neck Sizing Die	Bushing Bump Neck Sizing Die Kit (1 die & 3 bushings)	Bench Rest Seater Die	Ultra Micrometer Seater Die	1 Full Length Sizer + 1 Bench Rest Seater
7mm Rem Mag	005491	BBD3551	BBK2551 (.308", .306", .304")	006151	U00085	004401
7mm Rem Ultra Mag	005515	—	—	006115	U00086	004415
7mm Rem SA Ultra Mag	005518	—	—	006118	U00087	004418
7mm STW	005521	—	—	007011	U00072	004341
7mm Wby Mag	005501	—	—	008881	U00204	007231
7mm WSM	005520	—	—	006120	U00090	004420
280 Rem (7mm Exp Rem)	005511	—	—	006171	U00088	004421
284 Win	005531	—	—	006181	U00089	004425
7.62x54 R	005481	—	—	006161	U00080	004391
30-06	005611	BBD3851	BBK2851 (.334", .332", .330")	006281	U00113	004521
30-30 Win	005541	—	—	006201	U00097	004451
30-378 Wby Mag	005681	—	—	009031	U00207	007381
300 AAC Blackout	005545	—	—	006205	U00099	004453
300 Norma Mag	005548	—	—	006206	U00096	004455
300 PRC	005549	—	—	006207	U00114	004456
300 Rem Ultra Mag	005551	—	—	006211	U00098	004461
300 Rem SA Ultra Mag	005565	—	—	006215	U00095	004465
300 Wby Mag	005631	—	—	009011	U00205	007361
300 Win Mag	005561	BBD3651	BBK2651 (.334", .332", .330")	006221	U00100	004471
300 WSM	005571	BBD3701	BBK2701 (.337", .335", .333")	006231	U00101	004481
303 British	005581	—	—	006241	U00103	004491
308 Win <sup>(1)</sup>	005591	BBD3751	BBK2751 (.336", .334", .332")	006251	U00107	004501
308 National Match <sup>(1)</sup>	018311	—	—	006251	U00107	018331
308 Small Base <sup>(1)</sup>	SIZER308SB	—	—	—	—	018335
325 WSM	005721	—	—	006301	U00126	004531
8x57 Mauser	005651	—	—	006321	U00122	004561
8x68S	023541	—	—	023791	U00125	022291
338 Norma Mag	005665	—	—	006345	U00129	004575
338 Win Mag	005671	—	—	006331	U00128	004581
340 Wby Mag	005691	—	—	009021	U00206	007371
338 Lapua Mag	005661	—	—	006341	U00127	004571
375 H&H	005741	—	—	006361	U00134	004651
375 Rem Ultra Mag	005731	—	—	006351	U00133	004641

**Note (1):** See Fig. 8.

**Fig. 8 Differences between our .308 Caliber Full Length Sizing Dies**

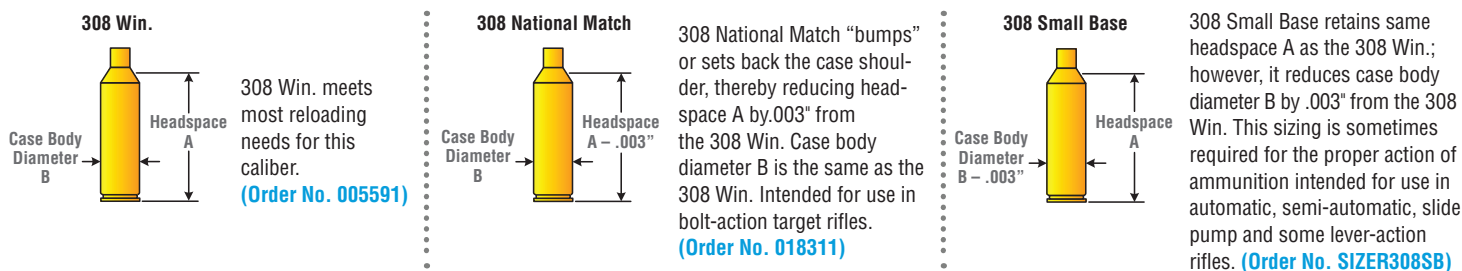

310 SE Lanark Avenue  
 Lanark, Illinois 61046  
 P: 815-493-6360 • F: 815-493-2371  
[forsterproducts.com](http://forsterproducts.com)

**WARRANTY**

All Forster Products are warranted against defects in materials and workmanship for the life of the product. Parts excluded from the warranty are those that, by nature of their function, are subject to normal wear (such as springs, pins, etc.) or that have been altered, abused, or neglected. If the product is deemed defective by workmanship or materials, it will be repaired, reconditioned or replaced (at Forster's option). This warranty supersedes all other warranties for Forster Products, whether written or oral.

ISO 9001: 2015 accredited

HG0001 Issue 7, June 2020