

An Accessory for Every Stage of the Case Conditioning Process

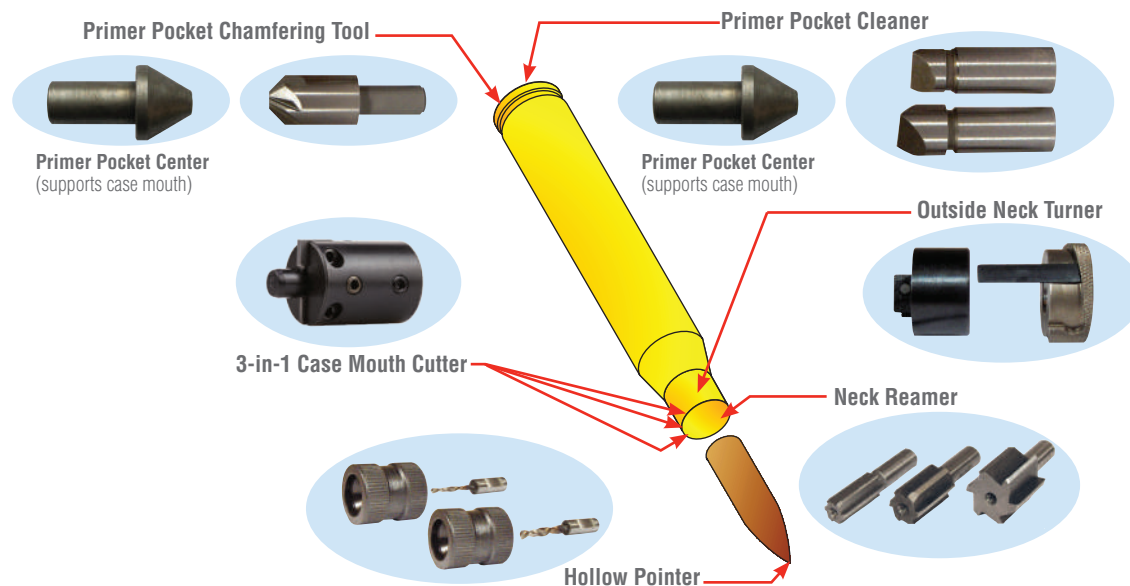

Accessory Name	Requirement	Function	Used on the Original Case Trimmer (CT1010) and the Power Case Trimmer (PT1010)	Used on the Classic Case Trimmer (CLCT00)
Outside Neck Turner	In terms of improved accuracy, no single reloading function provides a greater return on your time investment than turning eccentric case necks to a consistent wall thickness. If the brass is thicker on one side of the case than the other, the thin side releases the bullet first and causes a slight bullet-to-bore misalignment that can seriously impair accuracy. Note: We also offer a Hand-held Outside Neck Turner.	The Outside Neck Turner removes excess brass from the outside neck wall. When used after case sizing, this process produces neck walls of uniform thickness and exact outside neck diameter. Used after case sizing.	yes	no
Neck Reamer	At the point of ignition, brass must expand properly to release the bullet. Failure to have adequate clearance can ruin rifles and may even cause injury.	The Neck Reamer removes excess brass from the inside case neck wall, as well as the "dreaded donut" of material that can accumulate after repeated firings. Used before case sizing.	yes	yes
3-in-1 Case Mouth Cutter	One-step case trimming and deburring.	The 3-in-1 Case Mouth Cutter simultaneously chamfers the case neck inside and outside diameters and trims the case to length, all in one fast, easy step.	yes	no
Primer Pocket Cleaner (Used with the Primer Pocket Center)	Spent primer and powder residue must be removed after each firing to ensure consistent ignition and reduction of misfires.	The Primer Pocket Cleaner easily and quickly removes primer and powder residue.	yes	yes
Primer Pocket Chamfering Tool (Used with the Primer Pocket Center)	Crimp must be removed after firing to ensure proper seating of new primers.	The Primer Pocket Chamfering Tool chamfers military primer pockets, removing most, if not all, of the crimp from military cases.	yes	yes
Hollow Pointer	Precision shooters want to fine-tune bullet weight, which may improve ballistics, particularly when adjusting for different barrel twist. Hunters want to substantially increase bullet expansion on impact while using either factory cartridges or reloads.	The Hollow Pointer drills a cavity in the nose of cast or jacketed softnose bullets.	yes	yes

Case Trimmer Accessories

Outside Neck Turner

Turns your case neck concentric to its true axis, unlike hand-held neck turners which are centered only on the pilot. Use *after* the case neck has been resized and expanded.

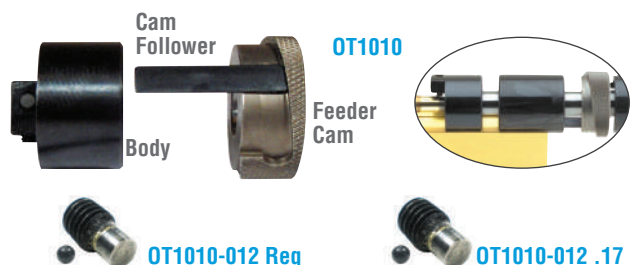

Features

- Adjustable, circular carbide cutter provides years of reliable use.
- Installs over the Case Trimmer Cutter Shaft.
- To operate, you control the rate of feed by rotating the feeder cam while a cam follower controls the length of the cut.
- To change calibers (any diameter from .204" to .375"), simply insert the correct Pilot and make the necessary adjustments to the carbide cutter.
- Properly adjusted, will turn necks to within a tolerance of $\pm .0001$ ".
- Cases longer than .375 Magnum (2.94") require a Long Case Trimmer Base (CT1010-CTB103).

Order No.	Description
OT1010	Outside Neck Turner
OT1010-012 Reg	Replacement Carbide Cutter
OT1010-012 .17 ⁽¹⁾	17 cal. Carbide Cutter

Note (1): Requires a 17 cal. Cutter Shaft.

Outside Neck Turner Pilots



Features

- This longer, hardened and ground Pilot of the desired caliber replaces the Pilot used when case trimming.
- Pilots are .0020" to .0025" smaller than bullet diameter.
- Outside Neck Turner Pilots **are not** interchangeable with the Hand Held Outside Neck Turner Pilots.

Order No.	Bullet Dia.	Pilot Dia.	Order No.	Bullet Dia.	Pilot Dia.
OT2017 ⁽¹⁾	.172"	.1685"	OT2308	.308"	.3055"
OT2204	.204"	.2015"	OT2311	.311"	.3085"
OT2224	.224"	.2215"	OT2323	.323"	.3205"
OT2243	.243"	.2405"	OT2333	.333"	.3305"
OT2257	.257"	.2545"	OT2338	.338"	.3355"
OT2264	.264"	.2615"	OT2358	.358"	.3545"
OT2277	.277"	.2745"	OT2375	.375"	.3725"
OT2284	.284"	.2815"			

Note (1): Requires a 17 cal. Cutter Shaft and a 17 cal. Carbide Cutter.

Custom Machining Services



Custom Pilots can be machined to your specifications.

Neck Reamers

Removes excess brass from inside the case neck wall. Use after the cases have been fired with a full load and before the neck or full-length sizing operation.



Features

- Manufactured from high-grade, wear-resistant tool steel.
- Staggered tooth design cuts brass smoothly without chattering.
- Installs in the Case Trimmer Cutter Shaft in place of the Pilot.
- Machined .0025" to .003" larger than bullet diameter.

Order No.	Bullet Dia.	Neck Reamer Dia.	Order No.	Bullet Dia.	Neck Reamer Dia.
NR1017 ⁽¹⁾	.172"	.1730"	NR1323	.323"	.3255"
NR1204	.204"	.2065"	NR1338	.338"	.3405"
NR1224	.224"	.2265"	NR1355	.355"	.3575"
NR1243	.243"	.2455"	NR1358	.358"	.3605"
NR1257	.257"	.2595"	NR1375	.375"	.3780"
NR1264	.264"	.2665"	NR1400	.400"	.4025"
NR1277	.277"	.2795"	NR1410	.410"	.4125"
NR1284	.284"	.2865"	NR1432	.429"	.4325"
NR1308	.308"	.3110"	NR1452	.452"	.4545"
NR1311	.311"	.3135"	NR1458	.458"	.4605"

Note (1): Requires a 17 cal. Cutter Shaft.

Wildcat conversions are so popular with the .224" and .243" bullet diameters that Forster Products offers Neck Reamers for these sizes as standard, off-the-shelf products. Use after the sizing operation.

Order No.	Bullet Dia.	Neck Reamer Dia.
NR1220	.224"	.2200"
NR1239	.243"	.2390"

Custom Machining Services



Neck Reamers can be machined to your specifications. Wildcat conversions often require custom-sized Neck Reamers when converting brass from one caliber to another.

Case Trimmer Accessories



Original Case Trimmer shown in use. Trim to length operation shown.

3-in-1 Case Mouth Cutter

Carbide blades simultaneously perform three functions in one simple step to save time and improve consistency (see Fig. 1).

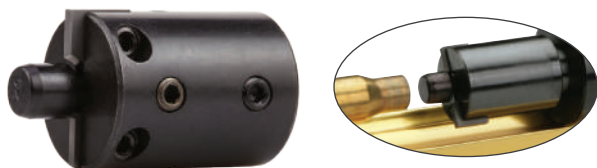

3CUT-XXX

- Trims the case to length.
- Chamfers the inside case mouth to an angle of 14°.
- Chamfers the outside case mouth to an angle of 30°.

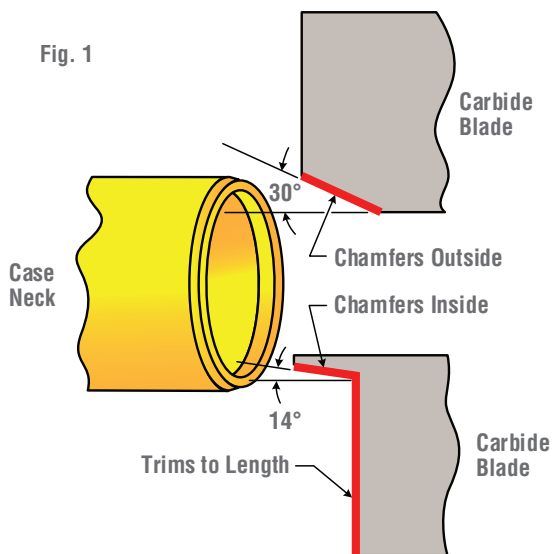

Features

- First three-in-one cutter on the market to use high-quality blades made from US-manufactured carbide. If used exclusively on brass cases, these blades should never need sharpening.
- Carbide cutter blades are factory adjusted on the blade holder, ensuring precise cutting.
- Installs by sliding over the Case Trimmer Cutter Shaft and secures with one set screw.

Order No.	Description
3CUT-224	3-in-1 Case Mouth Cutter for 224, includes Pilot
3CUT-243	3-in-1 Case Mouth Cutter for 243 (6mm), includes Pilot
3CUT-264	3-in-1 Case Mouth Cutter for 264 (6.5mm), includes Pilot
3CUT-277	3-in-1 Case Mouth Cutter for 277, includes Pilot
3CUT-284	3-in-1 Case Mouth Cutter for 284 (7mm), includes Pilot
3CUT-308	3-in-1 Case Mouth Cutter for 308, includes Pilot

Tip



For cases up to 2.20" long, use the base that comes with the Original Case Trimmer. For cases longer than 2.20", use a Long Base (CT1010-CTB103), which can handle cases from 1.0" to 3.30" when used with the 3-in-1 Case Mouth Cutter.

Case Trimmer Accessories

Primer Pocket Center

Supports the case mouth when used with the Primer Pocket Cleaner and the Primer Pocket Chamfering Tool.

PPCE02



Order No.	Description
PPCE02	Primer Pocket Center

Primer Pocket Cleaner

Quickly and easily removes powder and primer residue without cutting into the primer pocket web.

PPC175



PPC210



Features

- Manufactured from high alloy steel.
- Installs in the Case Trimmer Cutter Shaft in place of the Pilot.
- Used with the Primer Pocket Center (PPCE02, above) to support the case mouth.
- Hold the case mouth over the Primer Pocket Center with one hand and turn the Case Trimmer handle with the other.

Order No.	Description
PPC175	Small Primer Pocket Cleaner for .175" Primers (Primer Pocket Center sold separately)
PPC210	Large Primer Pocket Cleaner for .210" Primers (Primer Pocket Center sold separately)

Primer Pocket Chamfering Tool

A quick and accurate method to remove military primer pocket crimp.

PPCT01



Features

- Manufactured from tool steel.
- Staggered tooth cutter design cuts brass smoothly without chattering.
- Installs in the Case Trimmer Cutter Shaft in place of the Pilot.
- Used with the Primer Pocket Center (PPCE02, shown on this page) to support the case mouth.
- Hold the case mouth over the Primer Pocket Center with one hand and turn the Case Trimmer handle with the other. Control the depth and uniformity of the cut by setting the stop collar on the Case Trimmer.

Order No.	Description
PPCT01	Primer Pocket Chamfering Tool (Primer Pocket Center sold separately)

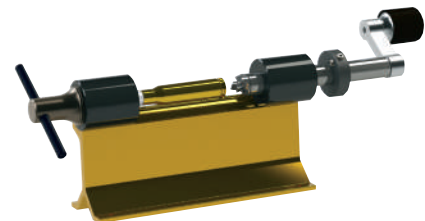
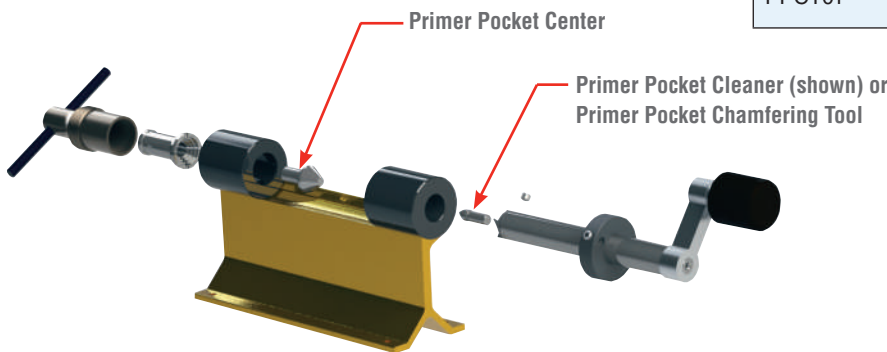

Our Customers Say



I recently bought a .308 Case Mouth Trimmer, and wanted you to know it worked great and saved so much time.

Grand Junction, CO

Case Trimmer Accessories

Hollow Pointer

Improve performance and save money by making your own hollow-pointed rounds. Control the hollow point size and depth to fit your own requirements.

HP1008

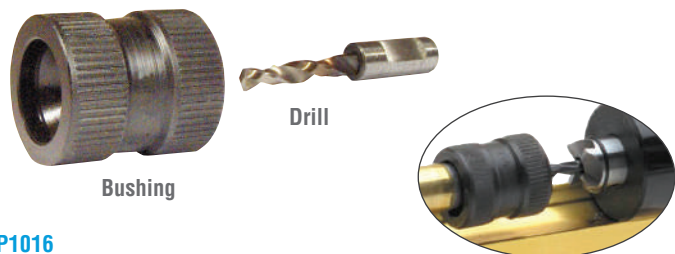

HP1016

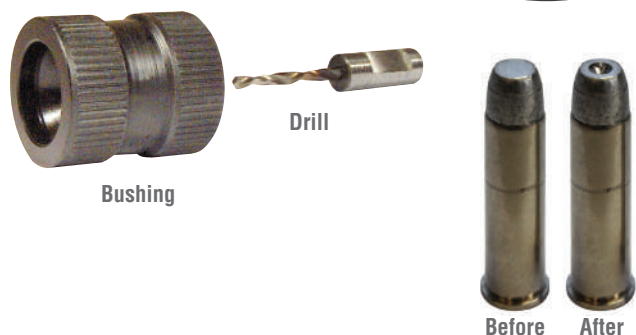

Features

- Only tool of its kind on the market.
- Available in either 1/8" (usually used for handgun rounds) or 1/16" (usually used for rifle rounds) drill sizes.
- Installs in the Case Trimmer Cutter Shaft in place of the Pilot.
- Install the Hollow Pointer drill into the Cutter Shaft. Place a loaded cartridge in the Case Trimmer Collet. The bushing centers the drill's tip against the nose of the bullet as the cartridge is locked in place. Control the hollow point depth by setting the stop collar of your trimmer.
- May require a Long (CT1010-CTB103) Case Trimmer Base for very long rounds.

Order No.	Description
HP1008	Hollow Pointer (1/8" drill size)
HP1016	Hollow Pointer (1/16" drill size)

Our Customers Say



I am so pleased with your products. My handloads have improved significantly, and it shows on the range!

Memphis, TN

Accessory Case for Case Trimmer Parts

The perfect solution for keeping your Case Trimmer accessories organized and protected.

AC5000



Features

- Storage holes for:
 - Collets #1 through #4 (Original Case Trimmer Collets only)
 - 12 Pilots or Neck Reamers (any combination)
 - One Outside Neck Turner
 - One Primer Pocket Chamfering Tool with one Primer Pocket Center
 - Two Primer Pocket Cleaners
- Measures just 9" X 5"
- Made of tough, lightweight plastic that won't crack, peel or break, even under adverse conditions.

Notes:

- Sold separately without the accessories shown.
- Does not accommodate Classic Case Trimmer Collets (#5 through #8).

Order No.	Description
AC5000	Accessory Case for Case Trimmer Parts



310 SE Lanark Avenue
Lanark, Illinois 61046
P: 815-493-6360 • F: 815-493-2371
forsterproducts.com

WARRANTY

All Forster Products are warranted against defects in materials and workmanship for the life of the product. Parts excluded from the warranty are those that, by nature of their function, are subject to normal wear (such as springs, pins, etc.) or that have been altered, abused, or neglected. If the product is deemed defective by workmanship or materials, it will be repaired, reconditioned or replaced (at Forster's option). This warranty supersedes all other warranties for Forster Products, whether written or oral.

ISO 9001: 2015 accredited

HG0001 Issue 5, January 2019