

# FORSTER PRODUCTS

310 SE LANARK AVENUE, LANARK, ILLINOIS 61046 PHONE: 815-493-6360 FAX: 815-493-2371 forsterproducts.com

## User Instructions for Universal Sight Mounting Fixture

Issue 4

### 1.0 GENERAL INFORMATION

The Universal Sight Mounting Fixture (UF100) guarantees true spacing and alignment along single-barrel long guns – including bolt actions, lever actions, and pump actions – as long as the barrel can be laid into its V Block. Tubular magazine guns can be drilled in the same manner as other firearms by simply removing the magazine tube.

The Universal Sight Mounting Fixture, or USMF, was especially designed for accurately drilling and tapping rifle actions and barrels for top mounts and target scope blocks, receiver sights, ramp sights, and beads, as well as side mounts, whenever the mounting holes are in line with the centerline of the barrel. (Even when the action is not exactly in line with the barrel, USMF automatically allows you to drill holes true with the barrel.)

Figure 1. Mauser Barrel in Universal Sight Mounting Fixture



### 2.0 SAFETY INFORMATION

- Please follow all pertinent safety procedures such as wearing safety glasses, being in a well-lit and well-ventilated workspace, and having all gunsmithing tools in top working condition.
- Always follow manufacturer instructions for all power tools and mounted accessories.

### 3.0 ASSEMBLY

USMF is shipped partially assembled (Fig. 4).

Additional components (Fig. 2) are included in the package for adjusting the fixture to fit your barrel:

- One 3/16" Hex Key Wrench (HEXWRENCH3/16)
- Two Aluminum Pads (UF1000-017).
- One Center Locating Pin (UF1000-015).
- Three bushings in a drill bushing set (UF1000-UB0648). See Table 1 for details.

Figure 2. Addnl. Components

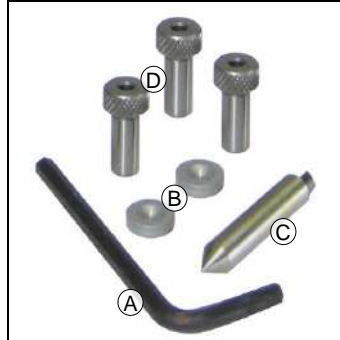

Table 1. Bushing Sets

Order No.	Dimensions
UF1000-UB0356	3-56 Bushing Set (2 Bushings), Marked #45 (drill), #36 (tap)
UF1000-UB0648	6-48 Bushing Set (3 Bushings), Marked #7/64 (pre-drill), #31 (drill), #27 (tap)
UF1000-UB0840	8-40 Bushing Set (3 Bushings), Marked #30 (pre-drill), #28 (drill), #18 (tap)
UF1000-UB1032	10-32 Bushing Set (3 Bushings), Marked #25 (pre-drill), #21 (drill), #9 (tap)

### 4.0 PREPARE THE FIREARM

First, remove the stock from the gun to be drilled and tapped. It is usually not necessary to remove the trigger mechanism on bolt actions.

Some types of firearms have unique construction – for example,

- Savage 99 requires only the removal of the forearm.
- Remington 760 requires the removal of the slide and slide bolt, as well as the bolt mechanism. The barrel can then be held to the action with a standard 3/8" x 24 hex nut.
- Tubular magazine rifles must have the magazine removed before drilling.

### 5.0 SECURE BARREL IN USMF

1. Set the barrel into the V Blocks (UF1000-102), with the action over the Clearance Slot (Fig. 3).

Whenever possible, position the barrel so that the action is close to the rear V Block, with the cylindrical or straight portion of the barrel supported by the front V-block.

Figure 3. USMF Contact Points (V Block Clamps Not Shown)

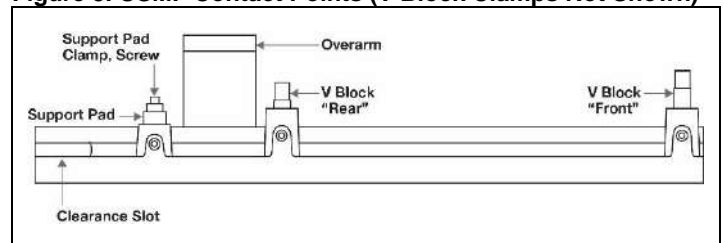

2. Slide the Overarm in place over the portion of the action to be drilled.
3. Loosen the adjustment screw (UF1000-036), raise the rear V Block to bring the action into contact with the drill Bushing in the Overarm, and tighten the screw.
4. Next, adjust the front V Block to secure the muzzle end of the barrel. Since most barrels are tapered, it will be necessary to raise the front V Block higher than the rear, as follows:
  - a. Using a micrometer or calipers, measure the diameter of the barrel where it contacts the front and rear V Blocks.

- b. To calculate the exact difference in height, subtract the small diameter from the larger diameter, and multiply this value by 0.707.
- c. Loosen the adjustment screw, raise the front V Block to the height of the rear V Block plus the value you received in calculation 4.b., above, and then tighten the screw.

A machinist's rule will satisfactorily measure the correct height. If extreme accuracy is needed, employ a feeler gauge between the top of the machined boss and the bottom of the V Block.

5. Next, clamp the barrel lightly, in both V Blocks, using the Aluminum Pads under the C Clamp screws to avoid marring the barrel.
6. On bolt actions, raise the flat-top Support Pad (UF1000-103) into firm contact with the flat bottom of the action. The Pad squares up the action and supports the barrel during drilling. Tighten the Support Pad Clamp (UF1000-021).

Actions that have no flat bottom surface can be lined up by means of a square from either the top of the Overarm or any other machined surface on USMF. The gun also can be lined up by use of a level, as long as USMF itself is first level.

#### TIP



It is good practice to make sure that the V Blocks line up squarely by tightening the screws gently at first, so that the flat of the screw squarely contacts the flat of the shaft. A twisted V Block will throw off the alignment due to the taper in the barrel, especially when the barrel is supported at a point where the taper is abrupt.

### 6.0 DRILL HOLES FOR MOUNTS

1. With the barrel now secured, place the mount on the action or barrel in the desired position and mark the forward hole on the gun with a scribe or pencil.
2. Point the Center Locating Pin (Fig. 2) into the front hole of the Overarm, and slide the Overarm over the gun until the Pin lines up with the mark.
3. Tighten the Overarm's T Slot adjustment screw (UF1000-034).
4. Drill and tap the first hole.
5. Fasten the mount to the gun with one screw.
6. Loosen the Overarm and, with the tapered point of the Locating Pin, slide the Overarm over the second hole in the mount.
7. Tighten the Overarm's T Slot adjustment screw, and also lock the spacer Stop Block (UF1000-013) against the Overarm.
8. Now slide the Overarm out of the way, remove the mount, and line the Overarm back against the Spacer Block.
9. Drill and tap the second hole.

Repeat steps 6. through 9. to drill any other holes in the mount.

Do not drill the holes with the mount in place, as this may prevent drilling on the true center of the action.

### 7.0 DRILL HOLES FOR RECEIVER SIGHTS OR SIDE MOUNTS

1. Line up the barrel in the V Blocks in the usual way (see section 5.0, "Secure Barrel in USMF"), but turn the action sideways and square it up by means of a small square laid on top of the Overarm.
2. Locate the first hole and proceed as outlined above (see section 6.0, "Drill Holes for Mounts").

This procedure also applies to mounting side mounts, as long as all holes lie along the centerline of the barrel. If the side mount's holes are not on the centerline of the barrel, you may still use USMF to hold the gun squarely and steadily in the drill press, but you would not be able to drill through the bushings in the Overarm.

### 8.0 DRILL HOLES FOR RAMP SIGHTS AND SHOTGUN BEADS

1. Insert the barrel into USMF "backwards," with the muzzle end toward the Clearance Slot.
2. Raise the V Blocks high enough so that the drill bushings will contact the barrel.

In this case, as well, you must allow for the taper in the barrel as explained above in section 5.0, "Secure Barrel in USMF," step 4., though it is necessary to square up the gun with a level.

3. Proceed slowly and carefully, double-checking the setup to be sure that you are drilling the holes exactly where you want them (see section 6.0, "Drill Holes for Mounts").

### 9.0 ORDERING INFORMATION

We recommend ordering from a dealer or distributor. Their experience and knowledge will help you select the best products that meet your specific requirements. In addition, they usually offer the best prices and convenient delivery options.

To find a Reseller, go to [forsterproducts.com](http://forsterproducts.com) and click **Distributors**. If your distributor cannot supply you, or if you need parts, please contact Forster Products directly by email, phone, or fax.

Figure 4. Universal Sight Mounting Fixture Isometric Diagram and Replacement Parts

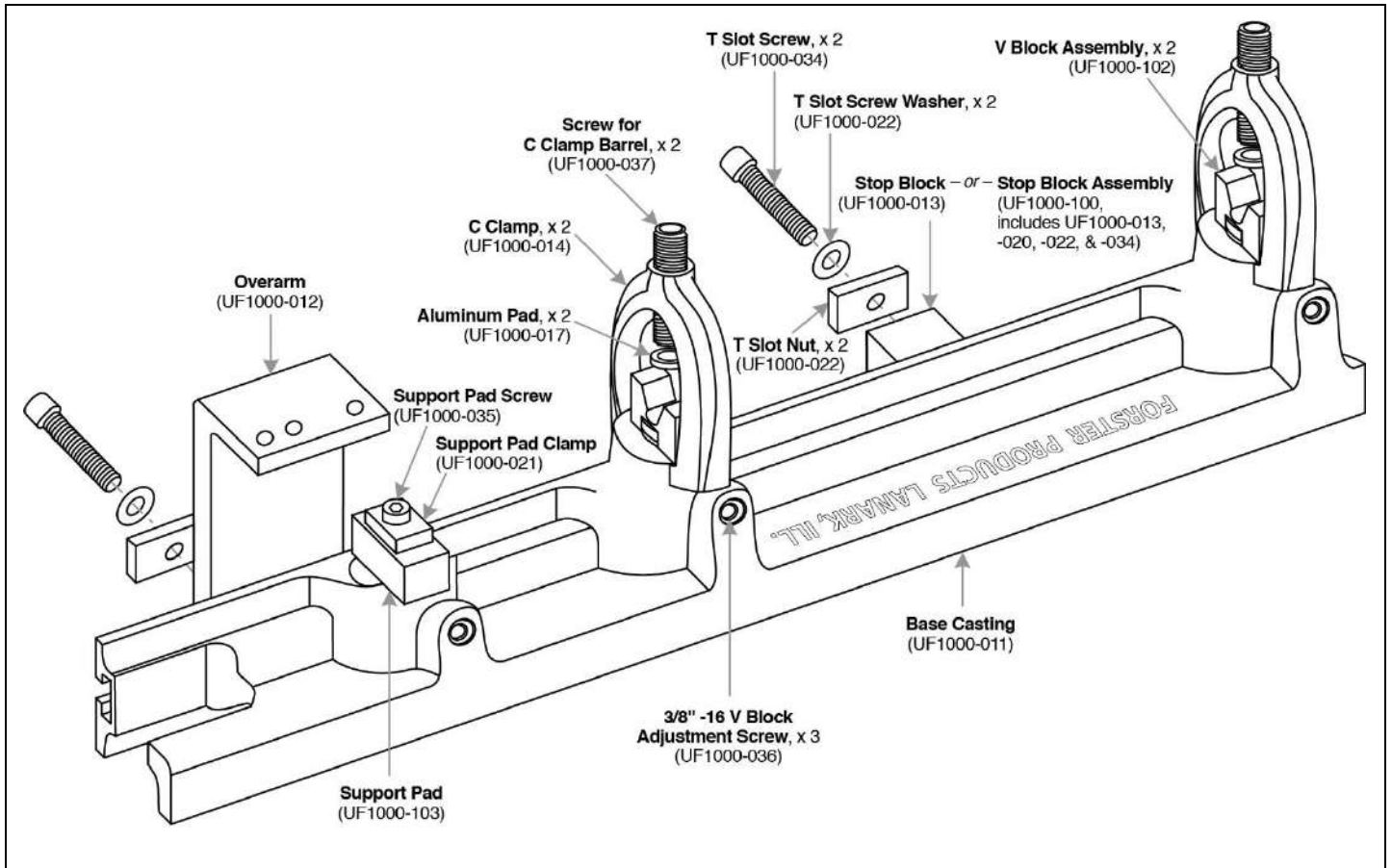

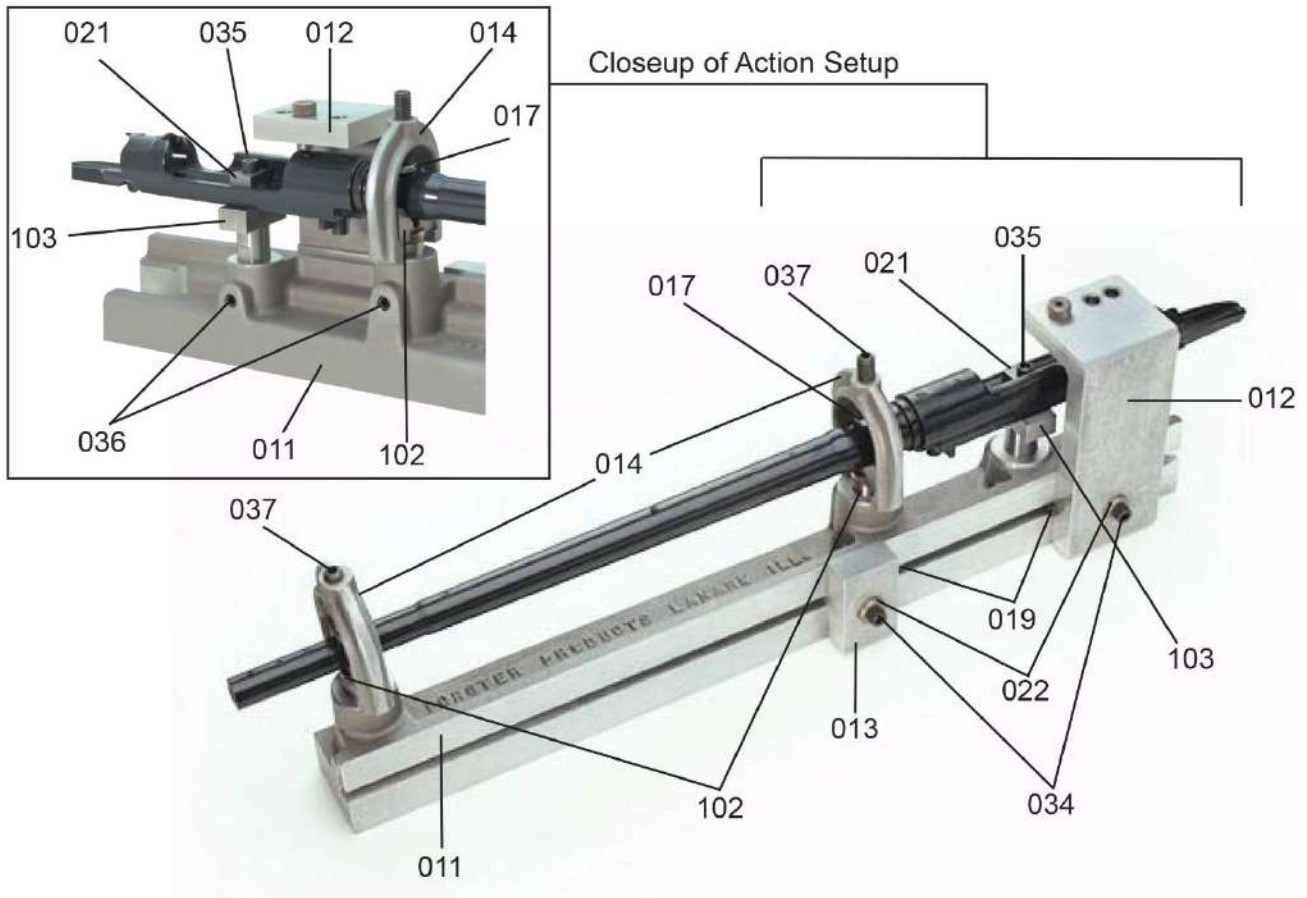

Part number	Description
UF1000	Universal Sight Mounting Fixture
UF1000-011	Base casting (machined)
UF1000-012	Overarm casting (machined)
UF1000-013	Stop block
UF1000-014	C-clamp casting
UF1000-015 (not shown)	Locating pin (center)
UF1000-017	Aluminum pad (2)
UF1000-019	Stop screw for overarm and stop block (2)
UF1000-020 (not shown)	T-slot nut for overarm and stop block (2)
UF1000-021	Support pad clamp
UF1000-022	Washer for overarm and stop block (2)
UF1000-034	T-slot screw for overarm and stop block (2)
UF1000-035	Screw for support pad shaft/clamp assembly
UF1000-036	3/8"-16 screw for two V blocks and support pad (3)
UF1000-037	Screw for barrel "C" clamps
UF1000-100	Stop block assembly (P/Ns 13, 20, 22, 34)
UF1000-102	V block (assembled) (2)
UF1000-103	Support pad (assembled)

**WARRANTY**

All Forster Products are warranted against defects in materials and workmanship for the life of the product. Parts excluded from the warranty are those that, by nature of their function, are subject to normal wear (such as springs, pins, etc.) or that have been altered, abused, or neglected. If the product is deemed defective by workmanship or materials, it will be repaired, reconditioned or replaced (at Forster's option). This warranty supersedes all other warranties for Forster Products, whether written or oral.