

FORSTER PRODUCTS

310 E. LANARK AVENUE, LANARK, ILLINOIS 61046 PHONE: 815-493-6360 FAX: 815-493-2371 www.forsterproducts.com

User Instructions for Neck Reamers

Issue 4

1.0 GENERAL INFORMATION

NOTE

Standard Neck Reamers must be used *after* the case has been fired with a full load and *before* the neck or full-length sizing operation.

TIP

A good rule of thumb is to ream after firing or turn after sizing.

The Neck Reamer removes excess brass from the inside neck walls of cartridge cases. Thick case necks have the potential to cause high chamber pressures and flyers.

High-grade tool steel and a staggered-tooth design enable the Neck Reamer to cut brass smoothly without chatter.

The Neck Reamer mounts in the cutter of a Forster Case Trimmer in place of the Pilot. This accessory is designed for the Original Case Trimmer (CT1010), the Classic Case Trimmer (CLCT00), and the Power Case Trimmer (PT1010). When using the Power Case Trimmer, always set the drill press spindle to its lowest speed.

Standard Neck Reamers (Fig. 1) are ground .0025" to .0030" larger than the bullet diameter. Forster Products offers a wide range of standard sizes (search by caliber at forsterproducts.com).

Figure 2. Original Case Trimmer with Neck Reamer



Figure 1. Wide Range of Sizes



An important exception to the standard Neck Reamer dimensions and guidelines is for **wildcat cartridges**. Wildcatters often require custom-sized Neck Reamers when converting brass from one caliber to another – *after* the sizing operation. Wildcat conversions are so popular that Forster Products offers standard, off-the-shelf Neck Reamers for .224" (NR1220) and .243" (NR1239) diameter bullets and may be used after resizing.

Note that, due to its smaller shank diameter, the Neck Reamer for the .172" bullet diameter (NR1017) also requires the 17 Caliber Cutter Shaft (CT1010-CTC417).

2.0 SAFETY INFORMATION

Always wear safety glasses.

3.0 PREPARATION AND PROCEDURE

1. Fasten your Case Trimmer securely to a bench or board to allow the free use of both hands.
2. Insert the shank of the Neck Reamer into the pilot hole of the cutter shaft, and tighten the set screw (Fig. 3).

Figure 3. Neck Reamer Assembly

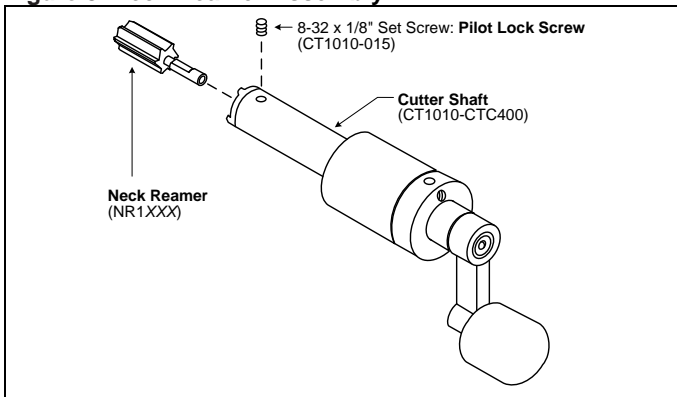

3. Select the proper Case Trimmer Collet, and remove the Collet Screw from the Collet Housing. Apply a small amount of grease to the front face, tapered portion, and base of the Collet.
4. Place the Collet back into the Collet Screw and Housing (Fig. 4).

Figure 4. Case Trimmer Collet Configuration

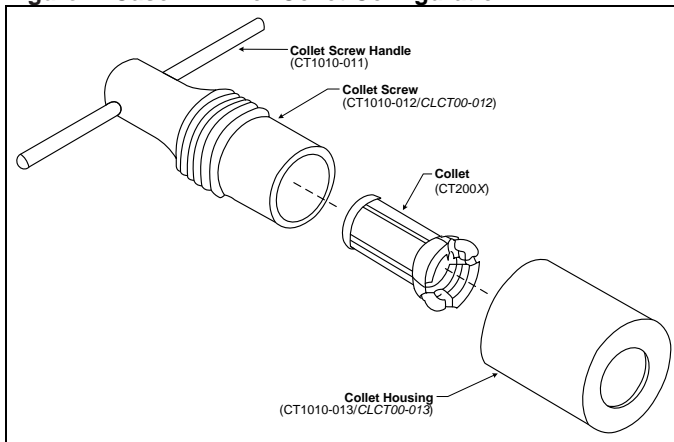

5. With tension on the Collet released, insert the base of the case into the Collet.
6. To aid in centering the case, insert the front angle of the Neck Reamer into the case neck.
7. While keeping the front angle of the Neck Reamer engaged in the mouth of the case, push the base of the case firmly against the bottom of the Collet, and then tighten the Collet Screw with your other hand.

Figure 5. Neck Reamer in Use



8. Using a light, inward pressure and smooth turning action with the crank, ream the case neck.
9. Continue to turn the crank clockwise while withdrawing the Neck Reamer from the case neck.
10. Brush the chips away from the Neck Reamer after each case is reamed to ensure a fine finish on the neck's cut.

After using the Forster Inside-Outside Deburring Tool (DB1000), the case is now ready for the Neck or Full Length Sizing Die.

4.0 MEASURING NECK WALL THICKNESS

You can measure wall thickness with a Forster Case and Cartridge Inspector (010482) or a tubing micrometer, but a simpler test for excess brass is to slide a bullet into a fired, unsized case neck. If you feel interference, ream the inside of the neck or turn it from the outside.

5.0 ORDERING INFORMATION

See www.forsterproducts.com for complete documentation and part numbers, including Pilots and Collets.

For best prices, contact your Forster distributor. Experienced distributors and wholesalers are an integral part of the shooting sports. Please make frequent use of their knowledge and support them. If your distributor or wholesaler cannot supply you, please contact us by email, fax or phone.

Custom-machined Neck Reamers are also available for an additional machining fee. Please specify the exact diameter.

Table 1. Neck Reamers

Order No.	Bullet Dia.	Neck Reamer Dia.	Order No.	Bullet Dia.	Neck Reamer Dia.
NR1017 ¹	.172"	.1730"	NR1311	.311"	.3135"
NR1204	.204"	.2065"	NR1323	.323"	.3255"
NR1224	.224"	.2265"	NR1338	.338"	.3405"
NR1220 ²	.224"	.2200"	NR1355	.355"	.3575"
NR1239 ²	.243"	.2390"	NR1358	.358"	.3605"
NR1243	.243"	.2455"	NR1375	.375"	.3780"
NR1257	.257"	.2595"	NR1400	.400"	.4025"
NR1264	.264"	.2665"	NR1410	.410"	.4125"
NR1277	.277"	.2795"	NR1432	.429"	.4325"
NR1284	.284"	.2865"	NR1452	.452"	.4545"
NR1308	.308"	.3110"	NR1458	.458"	.4605"

1. 17 caliber cases also require a 17 Caliber Cutter Shaft (CT1010-CTC417)
2. Popular wildcat diameters calibers may ream after sizing

WARRANTY

All Forster Products are warranted against defects in materials and workmanship for the life of the product. Parts excluded from the warranty are those that, by nature of their function, are subject to normal wear (such as springs, pins, etc.) or that have been altered, abused, or neglected. If the product is deemed defective by workmanship or materials, it will be repaired, reconditioned or replaced (at Forster's option). This warranty supersedes all other warranties for Forster Products, whether written or oral.