

FORSTER PRODUCTS

310 E. LANARK AVENUE, LANARK, ILLINOIS 61046 PHONE: 815-493-6360 FAX: 815-493-2371 www.forsterproducts.com

User Instructions for the Outside Neck Turner

Issue 7

1.0 GENERAL INFORMATION

The Outside Neck Turner (OT1010) turns case necks ranging from 22 caliber up to 375 caliber. It fits concentric to the true axis of the cartridge, unlike handheld outside neck turners, which center only on the pilot.

This accessory is designed for both the Original Case Trimmer (CT1010) and the Power Case Trimmer (PT1010). It does not fit onto the Classic Case Trimmer (CLCT00) or the 50 BMG Case Trimmer (50BMGCT).

Figure 1. Outside Neck Turner

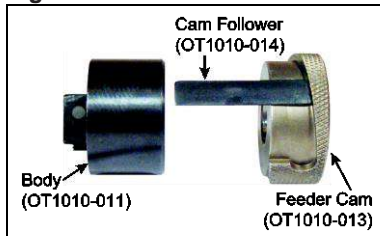

When a loaded round no longer has a clearance of .002" to .003" between the neck and the chamber of the gun, you must reduce the thickness of the neck wall. Inside Neck Reamers can establish the required

clearance, but the resulting neck walls will not have an even thickness. The Outside Neck Turner turns brass off the outside diameter *while* producing even neck walls.

3.0 CASE TRIMMER DIAGRAM

These instructions require familiarity with the standard components in a Case Trimmer (see User Instructions CT1010-002).

Figure 3. Original Case Trimmer

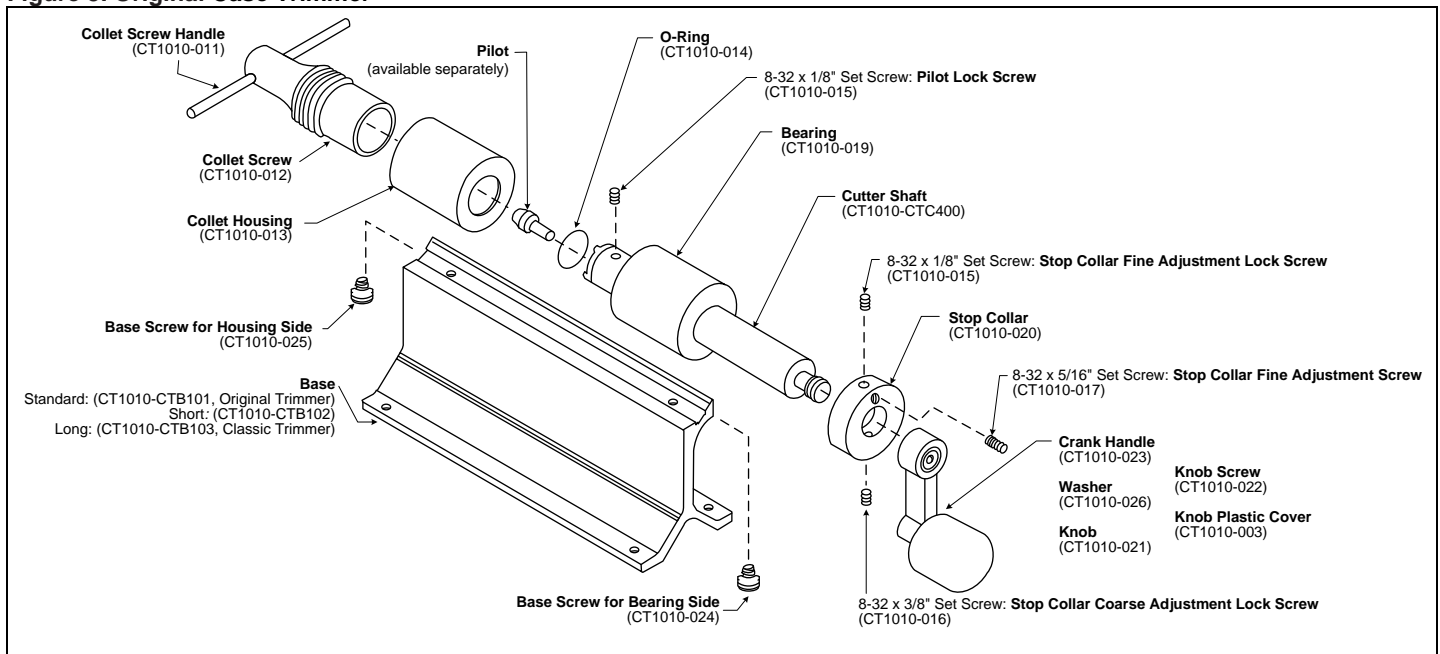

The Outside Neck Turner produces neck walls of uniform thickness and exact outside neck diameter to within a tolerance of .0001".

IMPORTANT NOTICE

Cases should have their necks resized and expanded *before* turning the outside of the necks.

Use the hardened and precision-ground Outside Neck Turner Pilot (Fig. 2) in place of the regular Case Trimmer Pilot. Order pilots (OT2XXX) separately. Pilots are made .0020" to .0025" smaller than the bullet's diameter. Forster Products offers many standard sizes, and custom-machined pilots are available for an additional machining fee.

Figure 2. Outside Neck Turner Pilot



2.0 SAFETY INFORMATION

Always wear safety glasses. Take precaution around cutters and sharp edges.

4.0 INSTALL THE OUTSIDE NECK TURNER ONTO THE CASE TRIMMER

1. Use four wood screws to fasten your Case Trimmer securely to a bench or board to allow the free use of both hands.
2. Remove the O-Ring (CT1010-014) from its groove in the Cutter Shaft (CT1010-CTC400).
3. Slide the Cutter Shaft and Crank Handle out of the Trimmer Bearing (CT1010-019), as shown in Fig. 4.

Figure 4. Case Trimmer Disassembled

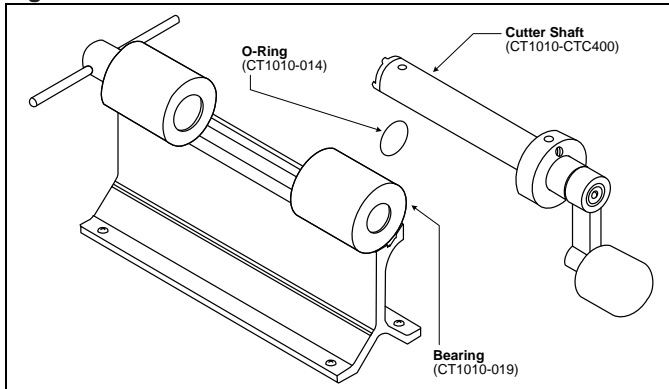

4. Select the proper Outside Neck Turner Pilot (OT2XXX) for your caliber, and insert the Pilot into the Cutter Shaft (see Fig. 5). Lock the Pilot in place by tightening the set screw (CT1010-015) against the flat on the shank of the Pilot.

Figure 5. Pilot Placement

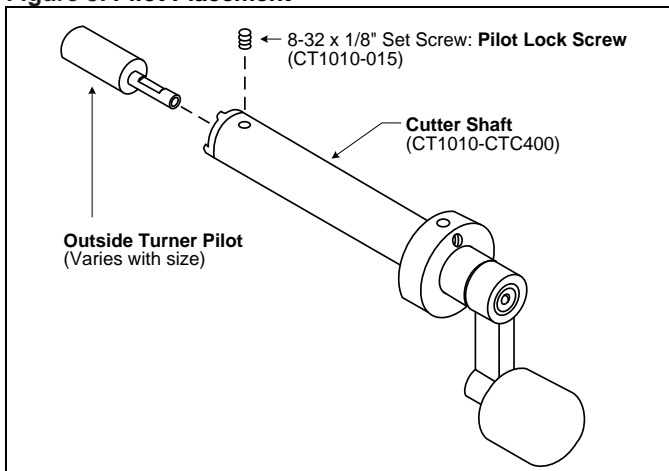

NOTICE

An adjustment of 1/2" (in 1/4" increments) is built into the Case Trimmer, allowing its capacity to be widened before it becomes necessary to use a Long Base (6 1/2"). To adjust, use the outer set of holes on the Collet Housing and Bearing to mount them to the Base.

5. Slip the Cam Follower (OT1010-014) – square cut end first – into the slot between the Trimmer Bearing and the Case Trimmer base (Fig. 6).

FORSTER VIDEO LIBRARY



Go to the online Video Library at forsterproducts.com and view "Outside Neck Turning: Cam Follower Insertion" to see a demonstration of this step.

Figure 6. Cam Follower Placement

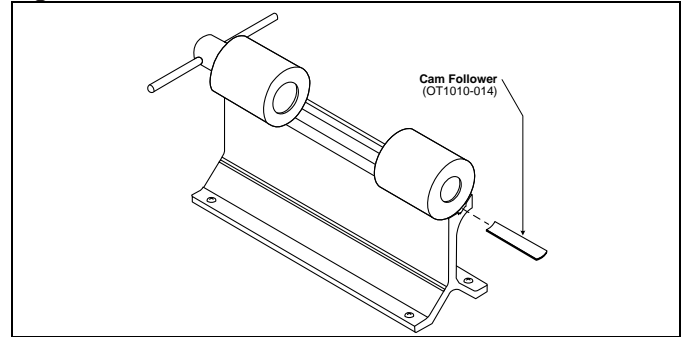

6. Slip the Feeder Cam (OT1010-013) onto the Cutter and slide it into contact with the Stop Collar (CT1010-020), as shown in Fig. 7.

Figure 7. Feeder Cam Follower Attached

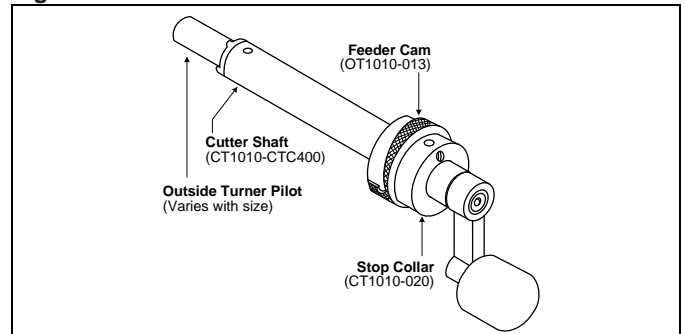

7. Replace the Cutter Shaft, Feeder Cam, and Stop Collar by sliding them through the Trimmer Bearing.
8. Slide the Cutter Body (OT1010-011) – carbide cutter end last – onto the Cutter Shaft, and tighten the Cutter Head Screw (SCR10-32 x 1/4").

Figure 8. Cutter Body Attached

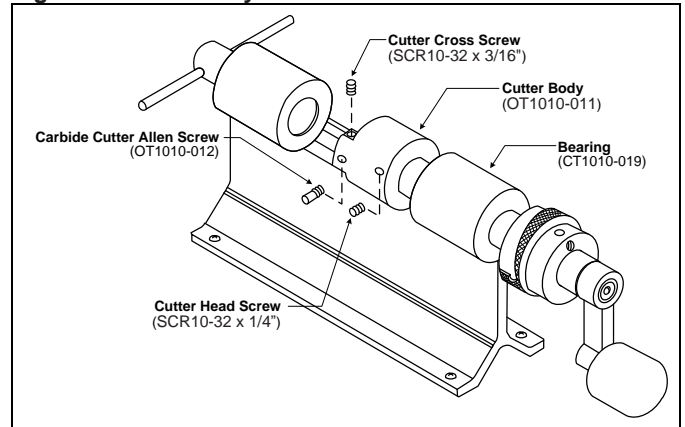

5.0 ALIGN THE CASE, CUTTER, AND CAM ALONG THE TRIMMER

1. Select the proper Collet (#1 to #4) for the case you will turn, and remove the Collet Screw (CT1010-012) from its Housing (CT1010-013). Apply a small amount of grease to the front face, the tapered portion, and the base, before reassembling the Collet.

Figure 9. Case Trimmer Collet Configuration

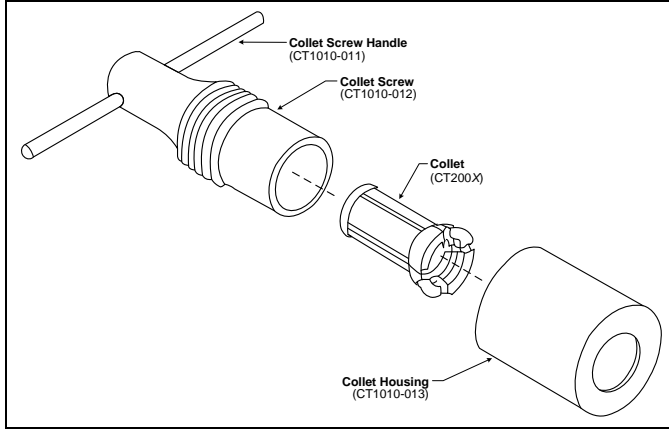

2. With tension on the Collet released, insert the base of the case to be turned into the Collet. Move the Outside Neck Turner Pilot (OT2XXX) about 1/2" into the neck of the sized case, as shown in Fig. 10.

FORSTER VIDEO LIBRARY



Go to the online Video Library at forsterproducts.com and view "Outside Neck Turning: Proper Case Alignment" to see a demonstration of this step.

3. Hold the case firmly against the bottom of the Collet with one hand, bottoming out on the Collet. Then, tighten the Collet Screw with your other hand to lock the case in place.

Figure 10. Case Firmly Seated

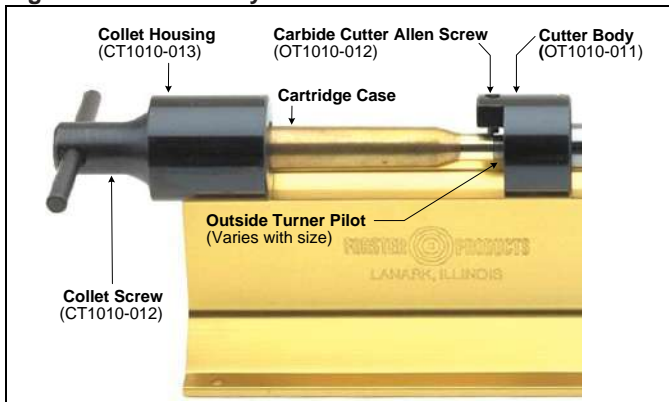

4. With the Cross Screw (SCR10-32 x 3/16) loosened, turn the Carbide Cutter Allen Screw (OT1010-012) clockwise until the carbide cutter is close to, but not in contact with, the case neck. Now, lock the Cross Screw against the Carbide Cutter Allen Screw.

Figure 11. Positioning the Cutter

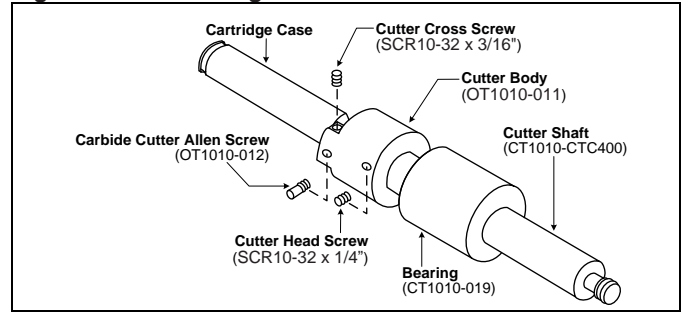

5. Slide the Feeder Cam (OT1010-013) into contact with the Cam Follower (OT1010-014). Rotate the Cam clockwise as far as possible. (See Fig. 12.)
6. Set the Stop Collar Fine Adjustment Screw (CT1010-017) so that the carbide cutter will stop cutting about 1/16" from the shoulder of the case.

Figure 12. Positioning the Stop Collar

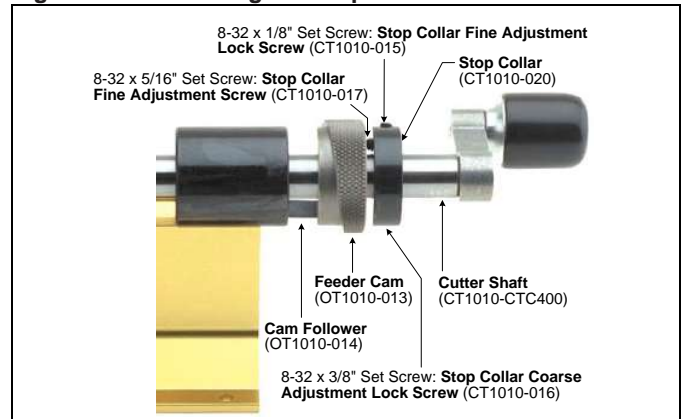

7. Move the Neck Turner Body (OT1010-011) so that the Carbide Cutter (OT1010-012) is not above the case neck, and then turn the Carbide Cutter 1/16 of a turn clockwise with the Allen wrench provided. (One full turn will move the Carbide Cutter approximately .032"; therefore, 1/16 of a turn will move the carbide cutter .002".) Tighten the Carbide Cutter Cross Screw (SCR10 10-32 X 3/16).

Figure 13. Carbide Cutter



CAUTION

A .002" adjustment of the Carbide Cutter reduces the resulting neck diameter by .004".

6.0 TURNING PROCEDURE

To turn the case neck, commonly known as “infeeding” the case trimmer to do the turning, follow the steps below:

1. Hold the Feeder Cam (OT1010-013) in place against the Cam Follower (OT1010-014) with one hand, while smoothly turning the crank handle clockwise with the other hand to rotate the carbide cutter (see Fig. 12, above).
2. Feed the Cam clockwise, slowly and evenly while continuing to turn the crank handle.

FORSTER VIDEO LIBRARY



Go to the online Video Library at forsterproducts.com and view “Outside Neck Turning: Proper Cutting Control” to see a demonstration of this procedure.

3. When you reach the stop, reverse the Cam feed by turning it counterclockwise, while continuing to turn the crank handle clockwise.
 - a) If the Carbide Cutter (OT1010-012) made a light cut, removing brass from the neck, continue with step #4. Otherwise, adjust the cutter toward the case neck another 1/16th revolution, and turn the case neck again. Continue to adjust the cutter down until it takes a light cut from the case neck.
4. Measure the case neck’s diameter with a micrometer or dial caliper. (Refer to a reliable reloading manual for the proper outside neck diameter.)
5. Adjust the Carbide Cutter accordingly to obtain the proper neck diameter setting. Since case necks frequently have high and low spots, you may achieve the correct diameter without removing brass from the entire perimeter of the neck.

CAUTION

Do not cut into the shoulder of the case.

6. Once you have turned the outside neck to the required diameter, set the length of the travel to just start blending the cut with the shoulder angle of the case. (Alternatively, some shooters turn only to the depth at which the bullet is seated.)
 - a) Begin turning the case neck again. Slow the Cam feed when the cutter approaches the shoulder of the case. When the cut almost blends with the shoulder angle, stop turning.
 - b) Set the Case Trimmer Stop Collar (CT1010-020) to stop the Carbide Cutter 1/16” from the shoulder of the case.

The Outside Neck Turner is now set up to turn an entire lot of cases. Just repeat the case alignment and turning procedure for each case. Measure the turned neck diameter occasionally to ensure accuracy.

7.0 ORDERING INFORMATION

See forsterproducts.com for complete documentation and part numbers, including pilots and collets.

For best prices, contact your Forster distributor. Experienced distributors and wholesalers are an integral part of the shooting sports. Please make frequent use of their knowledge and support them. If your distributor or wholesaler cannot supply you, please contact us by email, fax or phone.

Table 1. Outside Neck Turner and Accessories

Order Number	Description
OT1010*	Complete Kit
OT1010-011	Outside Neck Turner Body
OT1010-100	Outside Neck Turner Body with all screws installed
SCR10-32 x 3/16	Cutter Cross Screw
SCR10-32 x 1/4	Cutter Head Screw
OT1010-012 Reg	Replacement Carbide Cutter
OT1010-012 .17**	17 Caliber Carbide Cutter
OT1010-013	Feeder Cam
OT1010-014	Cam Follower
OT2XXX	Outside Neck Turner Pilot (order according to case diameter)

* Cases longer than 2.94” require a Long Case Trimmer Base (CT1010-CTB103).

** 17 caliber cases also require a 17 Caliber Cutter Shaft (CT1010-CTC417).

WARRANTY

All Forster Products are warranted against defects in materials and workmanship for the life of the product. Parts excluded from the warranty are those that, by nature of their function, are subject to normal wear (such as springs, pins, etc.) or that have been altered, abused, or neglected. If the product is deemed defective by workmanship or materials, it will be repaired, reconditioned or replaced (at Forster’s option). This warranty supersedes all other warranties for Forster Products, whether written or oral.